

# 11. Vitrinas Pastelería Pastry Display Cases

## VOLCANES, UNA GRAN FUERZA PRODUCTIVA

Desde enriquecer el suelo hasta la creación de nuevas masas de tierra. Desempeñan un papel vital en el enfriamiento periódicamente fuera del planeta.

Cuando la ceniza volcánica y compuestos como el dióxido de azufre son liberados en la atmósfera, pueden reflejar algunos de los rayos del sol de vuelta al espacio, lo que reduce la cantidad de energía térmica absorbida por la atmósfera.

Este proceso, conocido como "oscurecimiento global", por lo tanto tiene un efecto de enfriamiento en el planeta.

## VOLCANOES, A GREAT PRODUCTIVE FORCE

From enriching the soil to the creation of new land masses. They play a vital role in periodically cooling off the planet.

When volcanic ash and compounds such as sulphur dioxide are released into the atmosphere, they reflect some of the sun's rays back into space, which reduces the amount of thermal energy absorbed by the atmosphere.

This process, known as "global dimming", therefore has a cooling effect on the planet.





V. PASTELERIA  
PASTRY DISPLAY CASES



# 11. Vitrinas Pastelería

## Pastry Display Cases

<b>Serie / Series</b> <b>GLACE</b>	<b>Vitrina expositora con reserva para pastelería</b> <b>Mueble caja y decoraciones</b>	Pastry display case with storage Counter case and decorations	<b>474 - 479</b> <b>480 - 481</b>
<b>Serie / Series</b> <b>NIZA</b>	<b>Vitrina expositora para pastelería</b> <b>Mueble caja y decoraciones</b>	Pastry display case Counter case and decorations	<b>482 - 487</b> <b>488 - 489</b>
<b>Serie / Series</b> <b>LYON</b>	<b>Vitrina expositora para pastelería</b>	Pastry display case	<b>490 - 493</b>
<b>Serie / Series</b> <b>LYON VIENNOISERIE</b>	<b>Vitrina expositora para pastelería</b>	Pastry display case	<b>494 - 495</b>
<b>Serie / Series</b> <b>LYON CHOCOLATE</b>	<b>Vitrina expositora para pastelería</b>	Pastry display case	<b>496</b>
<b>Serie / Series</b> <b>LYON BAIN MARIE</b>	<b>Vitrina expositora para pastelería</b>	Pastry display case	<b>497</b>
<b>Serie / Series</b> <b>LYON LG</b>	<b>Vitrina expositora para pastelería vidrio bajo</b>	Pastry display case low glass	<b>498 - 501</b>
<b>Serie / Series</b> <b>LYON</b>	<b>Mueble caja y decoraciones</b>	Counter case and decorations	<b>502 - 503</b>
<b>Serie / Series</b> <b>AMBAR</b>	<b>Vitrina expositora con reserva para pastelería</b> <b>Vitrina caliente expositora para pastelería</b> <b>Vitrina expositora para pastelería autoservicio</b> <b>Vitrina Expositora para pastelería de doble servicio</b> <b>Decoraciones</b>	Pastry display case with storage Pastry hot display case Self service pastry display case Double service pastry display case Decorations	<b>504 - 507</b> <b>508 - 509</b> <b>510 - 511</b> <b>512</b> <b>513</b>
<b>Serie / Series</b> <b>AMBAR RECTA</b>	<b>Vitrina Muffin expositora pastelería/panadería</b> <b>Vitrina expositora para pastelería</b> <b>Vitrina caliente expositora para pastelería</b>	Muffin pastry an bakery display case Pastry display case Pastry hot display case	<b>516 - 517</b> <b>518 - 519</b> <b>520 - 521</b>
<b>Serie / Series</b> <b>ONIX</b>	<b>Vitrina expositora para pastelería</b> <b>Vitrina caliente expositora para pastelería</b> <b>Vitrina expositora pastelería cristal curvo</b> <b>Vitrina expositora para pastelería autoservicio</b>	Pastry display case Pastry hot display case Self service pastry curved glass display case Self service pastry display case	<b>522 - 525</b> <b>526 - 527</b> <b>528 - 529</b> <b>530 - 531</b>
<b>Serie / Series</b> <b>MARIE</b>	<b>Vitrina expositora para pastelería y panadería</b>	Pastry display case	<b>532 - 533</b>
<b>Serie / Series</b> <b>COMBO</b>	<b>Vitrina expositora para pastelería y panadería</b>	Pastry display case	<b>534 - 537</b>
<b>Serie / Series</b> <b>MAGNUS</b>	<b>Vitrina expositora frío ventilado modular con reserva</b> <b>Vitrina expositora modular neutra (panera)</b> <b>Mueble caja y decoraciones</b>	Refrigerated modular pastry display case Neutral modular display case Counter case and decorations	<b>538 - 543</b> <b>544</b> <b>545 - 547</b>
<b>Serie / Series</b> <b>CORAL</b>	<b>Vitrina expositora helados</b>	Gelato display case	<b>548 - 551</b>
<b>Serie / Series</b> <b>ARIES</b>	<b>Vitrina expositora helados</b>	Gelato display case	<b>552 - 553</b>
<b>Serie / Series</b> <b>CORAL &amp; ARIES</b>	<b>Decoraciones</b>	Decorations	<b>554 - 555</b>
<b>Serie / Series</b> <b>IBIZA</b>	<b>Vitrina expositora helado frío estático</b>	Ice crema static display case	<b>556 - 559</b>

# 11. Vitrinas Pastelería Pastry Display Cases

Serie / Series	DESCRIPCIÓN DESCRIPTION	PAG.
GLACE	<b>Vitrina expositora con reserva para pastelería</b> Pastry display case with storage	474 - 479
GLACE	<b>Mueble caja y decoraciones</b> Counter case and decorations	480 - 481
NIZA	<b>Vitrina expositora para pastelería</b> Pastry display case	482 - 487
NIZA	<b>Mueble caja y decoraciones</b> Counter case and decorations	488 - 489
LYON	<b>Vitrina expositora para pastelería</b> Pastry display case	490 - 493
LYON VIENNOISERIE	<b>Vitrina expositora para pastelería</b> Pastry display case	494 - 495
LYON CHOCOLATE	<b>Vitrina expositora para pastelería</b> Pastry display case	496
LYON BAIN MARIE	<b>Vitrina expositora para pastelería</b> Pastry display case	497
LYON LG	<b>Vitrina expositora para pastelería vidrio bajo</b> Pastry display case low glass	498 - 501
LYON	<b>Mueble caja y decoraciones</b> Counter case and decorations	502 - 503
AMBAR	<b>Vitrina expositora con reserva para pastelería</b> Pastry display case with storage	504 - 507
AMBAR	<b>Vitrina caliente expositora para pastelería</b> Pastry hot display case	508 - 509
AMBAR	<b>Vitrina expositora para pastelería autoservicio</b> Self service pastry display case	510 - 511
AMBAR	<b>Vitrina Expositora para pastelería de doble servicio</b> Double service pastry display case	512
AMBAR	<b>Decoraciones</b> Decorations	513

Válido para todo el catálogo. / Valid for the entire product guide.  
Fotografías no contractuales / Non contractual pictures.

Características técnicas y constructivas sujetas a variación sin previo aviso / We reserve the right to change specifications without prior notice.

Los datos técnicos están sujetos a posibles variaciones que serán actualizadas periódicamente en las fichas técnicas del producto, disponibles en la web.  
The technical data are subject to possible variations that will be updated periodically in the technical data sheets of the product, which are available on the website.

Serie / Series	DESCRIPCIÓN DESCRIPTION		PAG.
AMBAR RECTA	<b>Vitrina Muffin expositora pastelería/panadería</b> Muffin pastry an bakery display case		516 - 517
AMBAR RECTA	<b>Vitrina expositora para pastelería</b> Pastry display case		518 - 519
AMBAR RECTA	<b>Vitrina caliente expositora para pastelería</b> Pastry hot display case		520 - 521
ONIX	<b>Vitrina expositora para pastelería</b> Pastry display case		522 - 525
ONIX	<b>Vitrina caliente expositora para pastelería</b> Pastry hot display case		526 - 527
ONIX	<b>Vitrina expositora pastelería cristal curvo</b> Self service pastry curved glass display case		528 - 529
ONIX	<b>Vitrina expositora para pastelería autoservicio</b> Self service pastry display case		530 - 531
MARIE	<b>Vitrina expositora para pastelería y panadería</b> Pastry display case		532 - 533
COMBO	<b>Vitrina expositora para pastelería y panadería</b> Pastry display case		534 - 537
MAGNUS	<b>Vitrina expositora frío ventilado modular con reserva</b> Refrigerated modular pastry display case		538 - 543
MAGNUS	<b>Vitrina expositora modular neutra (panera)</b> Neutral modular display case		544
MAGNUS	<b>Mueble caja y decoraciones</b> Counter case and decorations		545 - 547
CORAL	<b>Vitrina expositora helados</b> Gelato display case		548 - 551
ARIES	<b>Vitrina expositora helados</b> Gelato display case		552 - 553
CORAL & ARIES	<b>Decoraciones</b> Decorations		554 - 555
IBIZA	<b>Vitrina expositora helado frío estático</b> Ice crema static display case		556 - 559



# Vitrina expositora con reserva para pastelería

## Pastry display case with storage



11



Serie  
**GLACE**  
Series







# Vitrina expositora con reserva para pastelería

Serie  
**GLACE**  
Series

## CARACTERÍSTICAS TÉCNICAS



### Línea modular

Línea modular, combinación de **módulos de diferentes sistemas de refrigeración**. Módulos con o sin reserva refrigerada. Ángulos y mostradores para adaptar la línea a un espacio.



### Comprobación de fuga de gas

Todos las unidades condensadoras son **comprobados al 100%, en cámara de Helio** para la detección de la fuga de gas.



### Iluminación

Incorporación de **iluminación LED**, llegando a **reducir el consumo energético entre un 80% y 90%** Iluminación en todos los niveles y frente para realzar los productos.

## TECHNICAL CHARACTERISTICS

### Modular line

Combination of **different cooling system modules**: ventilated, half-static and static. Modules with or without cooled storage. Angles and counters to adapt the line to a space.

### Leak detection system

All condenser units are **tested 100%, in helium chambers** to refrigerant leak detections.

### Lighting

**LED lighting** incorporated, **reducing energetic consumption between 80% and 90%** respect to a traditional light bulb.

VGL 15 C



VGL C

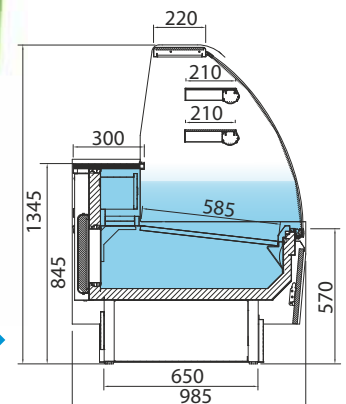

### MOD.

	Potencia Power (W)	Capacidad Capacity (L)	Nº puertas Doors	Superficie Exposición (m <sup>2</sup> )	Estantes Shelving	Compresor Compressor (HP)	LED	Consumo Consumption (kWh/24h)	Evaporación Evaporation	Potencia frigorífica Cooling capacity (W a -10°C)	Desescarche Defrost	Control	Refrigerante Coolant	De serie Standard
--	--------------------	------------------------	------------------	---	-------------------	---------------------------	-----	-------------------------------	-------------------------	---	---------------------	---------	----------------------	-------------------

VGL 9 C	300	163	1	0,9	2	1/4	✓	5,1	Semi Estática Semi Static	353	Manual	Digital	R 134a	Luz estantes y decoración
VGL 12 C	380	217	1	1,2	2	1/3	✓	5,4	Semi Estática Semi Static	414	Manual	Digital	R 134a	Luz estantes y decoración
VGL 15 C	410	271	2	1,5	2	3/8	✓	6,1	Semi Estática Semi Static	464	Manual	Digital	R 134a	Luz estantes y decoración
VGL 18 C	470	327	3	2,0	2	1/2	✓	6,4	Semi Estática Semi Static	568	Manual	Digital	R 134a	Luz estantes y decoración
VGL 25 C	630	430	4	2,6	2	5/8	✓	9,6	Semi Estática Semi Static	684	Manual	Digital	R 134a	Luz estantes y decoración



# Pastry display case with storage

Serie  
**GLACE**  
Series

## REFRIGERACIÓN



### Refrigeración

Reserva **refrigerada con ventiladores** (según modelo).  
Sistema de **Condensación Ventilada**.  
Sistema de **Evaporación semi estática**.

## REFRIGERATION

### Refrigeration system

**Refrigerated storage** with fans.  
**Ventilated condensation** system.  
**Semi-statique evaporation** system.

VGL 25 C



## Opcional / Optional

Puertas correderas traseras / Rear sliding doors:

VGL 9 [PUEVGL9C+]	<b>100 €</b>
VGL 12 [PUEVGL12C+]	<b>125 €</b>
VGL 15 [PUEVGL15C+]	<b>151 €</b>
VGL 18 [PUEVGL18C+]	<b>204 €</b>
VGL 25 [PUEVGL25C+]	<b>253 €</b>

CN Modelos neutros / Neutral models

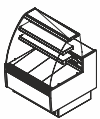

**VGL 9 C**  
**2.128 €**

998 x 985 x 1345 mm.  
Temp. +4°C/+8°C  
C. Clima. 3 / 25°C  
230v/1 ph/50 Hz

**VGL 9 CN**  
**1.794 €**

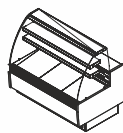

**VGL 12 C**  
**2.517 €**

1310 x 985 x 1345 mm.  
Temp. +4°C/+8°C  
C. Clima. 3 / 25°C  
230v/1 ph/50 Hz

**VGL 12 CN**  
**2.185 €**

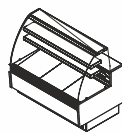

**VGL 15 C**  
**2.840 €**

1622 x 985 x 1345 mm.  
Temp. +4°C/+8°C  
C. Clima. 3 / 25°C  
230v/1 ph/50 Hz

**VGL 15 CN**  
**2.507 €**

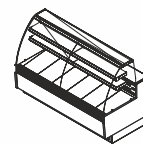

**VGL 18 C**  
**3.177 €**

1935 x 985 x 1345 mm.  
Temp. +4°C/+8°C  
C. Clima. 3 / 25°C  
230v/1 ph/50 Hz

**VGL 18 CN**  
**2.640 €**

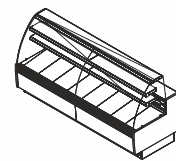

**VGL 25 C**  
**3.773 €**

2560 x 985 x 1345 mm.  
Temp. +4°C/+8°C  
C. Clima. 3 / 25°C  
230v/1 ph/50 Hz

**VGL 25 CN**  
**3.168 €**

Fotografías no contractuales / Non contractual pictures.

Características técnicas y constructivas sujetas a variación sin previo aviso / We reserve the right to change specifications without prior notice.

Los datos técnicos están sujetos a posibles variaciones que serán actualizadas periódicamente en las fichas técnicas del producto, disponibles en la web.

The technical data are subject to possible variations that will be updated periodically in the technical data sheets of the product, which are available on the website.

www.infrico.com



477



# Vitrina expositora con reserva para pastelería

Serie  
**GLACE**  
Series

## CARACTERÍSTICAS TÉCNICAS



### Control Digital

Mayor **precisión en el sistema de control de la temperatura y humedad**. Mayor facilidad para el ajuste del intervalo de temperaturas que deseamos conseguir.



### Comprobación de fuga de gas

Todos las unidades condensadoras son **comprobados al 100%, en cámara de Helio** para la detección de la fuga de gas.



### Iluminación

Incorporación de **iluminación LED**, llegando a **reducir el consumo energético entre un 80% y 90%** Iluminación en todos los niveles y frente para realzar los productos.

## TECHNICAL CHARACTERISTICS

### Digital control

Higher **precision in managing temperature settings**. Greater ability to adjust of temperature ranges as per the end user's requirement.

### Leak detection system

All condenser units are **tested 100%, in helium chambers** to refrigerant leak detections.

### Lighting

**LED lighting** incorporated, **reducing energetic consumption between 80% and 90%** respect to a traditional lighth bulb.

VGL 15 P

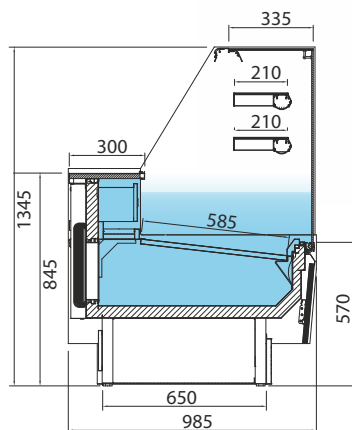

VGL P

MOD.



Potencia Power (W)



Capacidad Capacity (L)



Nº puertas Doors



Superficie Exposición (m<sup>2</sup>)



Estantes Shelving



Compresor Compressor (HP)



Consumo Consumption (kWh/24h)



Evaporación Evaporation



Potencia frigorífica Cooling capacity (W a -10°C)



Desescarche Defrost



Refrigerante Coolant



De serie Standard

	Potencia Power (W)	Capacidad Capacity (L)	Nº puertas Doors	Superficie Exposición (m <sup>2</sup> )	Estantes Shelving	Compresor Compressor (HP)	Consumo Consumption (kWh/24h)	Evaporación Evaporation	Potencia frigorífica Cooling capacity (W a -10°C)	Desescarche Defrost	Refrigerante Coolant	De serie Standard
VGL 9 P	300	163	1	0,9	2	1/4	5,1	Semi Estática Semi Static	353	Manual	R 134a	Luz estantes y decoración
VGL 12 P	380	217	1	1,2	2	1/3	5,4	Semi Estática Semi Static	414	Manual	R 134a	Luz estantes y decoración
VGL 15 P	450	271	2	1,5	2	3/8	6,1	Semi Estática Semi Static	464	Manual	R 134a	Luz estantes y decoración
VGL 18 P	470	327	3	2,0	2	1/2	6,4	Semi Estática Semi Static	568	Manual	R 134a	Luz estantes y decoración
VGL 25 P	630	430	4	2,6	2	5/8	9,6	Semi Estática Semi Static	684	Manual	R 134a	Luz estantes y decoración



# Pastry display case with storage

Serie  
**GLACE**  
Series

## REFRIGERACIÓN



### Refrigeración

Reserva **refrigerada con ventiladores** [según modelo].  
Sistema de **Condensación Ventilada**.  
Sistema de **Evaporación semi estática**.

## REFRIGERATION

### Refrigeration system

**Refrigerated storage** with fans.  
**Ventilated condensation** system.  
**Semi-statique evaporation** system.

VGL 25 P



## Opcional / Optional

Puertas correderas traseras / Rear sliding doors:

VGL 9 (PUEVGL9P+)	<b>100 €</b>
VGL 12 (PUEVGL12P+)	<b>125 €</b>
VGL 15 (PUEVGL15P+)	<b>151 €</b>
VGL 18 (PUEVGL18P+)	<b>204 €</b>
VGL 25 (PUEVGL25P+)	<b>253 €</b>

PN Modelos neutros / Neutral models



**VGL 9 P**  
**2.152 €**

938 x 985 x 1345 mm.  
Temp. +4°C/+8°C  
C. Clima. 3 / 25°C  
230v/1 ph/50 Hz

**VGL 9 PN**  
**1.811 €**

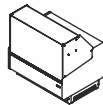

**VGL 12 P**  
**2.569 €**

1250 x 985 x 1345 mm.  
Temp. +4°C/+8°C  
C. Clima. 3 / 25°C  
230v/1 ph/50 Hz

**VGL 12 PN**  
**2.227 €**

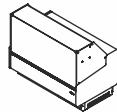

**VGL 15 P**  
**2.903 €**

1562 x 985 x 1345 mm.  
Temp. +4°C/+8°C  
C. Clima. 3 / 25°C  
230v/1 ph/50 Hz

**VGL 15 PN**  
**2.591 €**

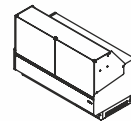

**VGL 18 P**  
**3.207 €**

1875 x 985 x 1345 mm.  
Temp. +4°C/+8°C  
C. Clima. 3 / 25°C  
230v/1 ph/50 Hz

**VGL 18 PN**  
**2.669 €**

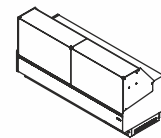

**VGL 25 P**  
**3.859 €**

2500 x 985 x 1345 mm.  
Temp. +4°C/+8°C  
C. Clima. 3 / 25°C  
230v/1 ph/50 Hz

**VGL 25 PN**  
**3.253 €**

Fotografías no contractuales / Non contractual pictures.

Características técnicas y constructivas sujetas a variación sin previo aviso / We reserve the right to change specifications without prior notice.

Los datos técnicos están sujetos a posibles variaciones que serán actualizadas periódicamente en las fichas técnicas del producto, disponibles en la web.

The technical data are subject to possible variations that will be updated periodically in the technical data sheets of the product, which are available on the website.

www.infrico.com



479



# Mueble caja y decoraciones

## Counter case and decorations

Serie  
**GLACE**  
Series

VGL 15 P



VGL 9 M

VGL 9 M



VGL 15



VGL M

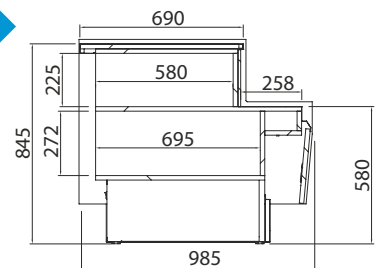

VGL 9 M  
**1.294 €**  
998 x 985 x 863 mm.

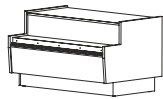

VGL 15 M  
**1.571 €**  
1622 x 985 x 863 mm.



VGL 90 AAM  
**2.471 €**  
1205 x 1140 x 863 mm.

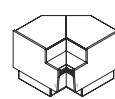

VGM 90 ACM  
**2.393 €**  
1045 x 766 x 863 mm.



VGL 12

RAL 3020  
Rojo / Red



VGL 12

RAL 4007  
Violeta / Violet



VGL 12

RAL 2003  
Naranja / Orange



VGL 12

RAL 5015  
Azul / Blue



VGL 12

RAL 1018  
Amarillo / Yellow



VGL 12

RAL 9017  
Negro / Black



## Decoración Standard / Standar Decorations

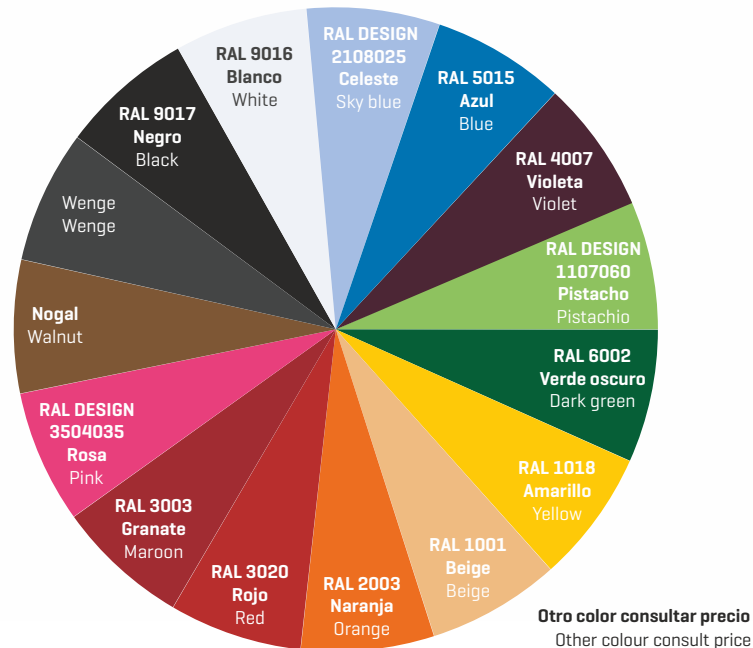

## Colores fuera de carta / Colors outside of letter

Color	Tipo Type	Incremento plazo de entrega Increase delivery time	Suplemento PVP (x pedido) PVP supplement [x order]
RAL	Epoxi	+10 días laborables/ Work days	675,00 €
	Líquida/Liquid	+10 días laborables/ Work days	420,00 €
NO RAL	Epoxi	Consultar/Consulter	Consultar/Consulter
	Líquida/Liquid	Consultar/Consulter	Consultar/Consulter





# Vitrina expositora para pastelería Pastry display case



Serie  
**NIZA**  
Series



Infrico

V. PASTELLERIA  
PASTRY DISPLAY CASES





# Vitrina expositora para pastelería

Serie  
**NIZA**  
Series

## CARACTERÍSTICAS TÉCNICAS



### Control Digital

Mayor **precisión en el sistema de control de la temperatura y humedad**. Mayor facilidad para el ajuste del intervalo de temperaturas que deseamos conseguir.



### Comprobación de fuga de gas

Todos las unidades condensadoras son **comprobados al 100%, en cámara de Helio** para la detección de la fuga de gas.



### Iluminación

Incorporación de **iluminación LED**, llegando a **reducir el consumo energético entre un 80% y 90%** Iluminación en todos los niveles y frente para realzar los productos.

## TECHNICAL CHARACTERISTICS

### Digital control

Higher **precision in managing temperature settings**. Greater ability to adjust of temperature ranges as per the end user's requirement.

### Leak detection system











All condenser units are **tested 100%, in helium chambers** to refrigerant leak detections.

### Lighting

**LED lighting** incorporated, **reducing energetic consumption between 80% and 90%** respect to a traditional light bulb.

VNZ 15



MOD.	 Costados Sides (mm)	 Potencia Power (W)	 Superficie Exposición (m <sup>2</sup> )	 Compresor Compressor (HP)	 LED	 Consumo Consumption (kWh/24h)	 Potencia frigorífica Cooling capacity (W a -10°C)	 Desescarche Defrost	 Control	 Refrigerante Coolant
VNZ9	20+20	750	0,60	1/4	✓	5,8	298	Automático Automatic	Digital	R-134a
VNZ12	20+20	795	0,80	1/3	✓	7	395	Automático Automatic	Digital	R-134a
VNZ15	20+20	870	1,00	3/8	✓	8,2	464	Automático Automatic	Digital	R-134a
VNZ18	20+20	920	1,20	1/2	✓	9,3	568	Automático Automatic	Digital	R-134a
VNZ12B	20+20	650	0,80	1/5	✓	6,1	254	Automático Automatic	Digital	R-134a
VNZ9DT	20+20	750	0,60	1/4	✓	7#7,4	298	Automático Automatic	Digital	R-134a
VNZ12DT	20+20	795	0,80	1/3	✓	5,8#9,9	395	Automático Automatic	Digital	R-134a
VNZ15DT	20+20	870	1,00	3/8	✓	8,2#12,4	464	Automático Automatic	Digital	R-134a
VNZ18DT	20+20	920	1,20	1/2	✓	9,3#14,8	568	Automático Automatic	Digital	R-134a

Fotografías no contractuales / Non contractual pictures.

Características técnicas y constructivas sujetas a variación sin previo aviso / We reserve the right to change specifications without prior notice.

Los datos técnicos están sujetos a posibles variaciones que serán actualizadas periódicamente en las fichas técnicas del producto, disponibles en la web. The technical data are subject to possible variations that will be updated periodically in the technical data sheets of the product, which are available on the website.



# Pastry display case

Serie  
**NIZA**  
Series

## REFRIGERACIÓN



### Refrigeración

Sistema de **Condensación Ventilada**.

Sistema de **Evaporación Forzada**.

**Control** de temperatura final de **desescarche**.

Bandeja **evaporativa** automática.

## REFRIGERATION

### Refrigeration system

System of **Ventilated Condensation**.

**Ventilated cooling** system.

**Defrost** end temperature **control**.

Automatic **evaporative** tray.

VNZ 12 + VNZ 15

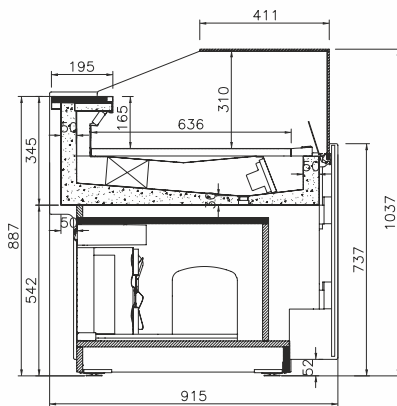

VNZ

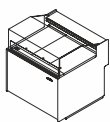

VNZ 9

**2.429 €**

938 x 915 x 1040 mm.  
Temp. +4°C / +8°C  
C. Clima. 3 / 25°C  
230v/1ph/50 Hz

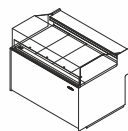

VNZ 12

**2.718 €**

1250 x 915 x 1040 mm.  
Temp. +4°C / +8°C  
C. Clima. 3 / 25°C  
230v/1ph/50 Hz

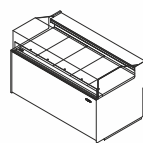

VNZ 15

**3.032 €**

1562 x 915 x 1040 mm.  
Temp. +4°C / +8°C  
C. Clima. 3 / 25°C  
230v/1ph/50 Hz

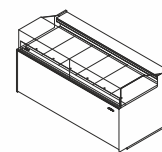

VNZ 18

**3.361 €**

1875 x 915 x 1040 mm.  
Temp. +4°C / +8°C  
C. Clima. 3 / 25°C  
230v/1ph/50 Hz

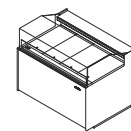

VNZ 12 B

**2.867 €**

1250 x 915 x 1040 mm.  
Temp. +4°C / +8°C  
C. Clima. 3 / 25°C  
230v/1ph/50 Hz

VNZ 9 DT

**3.103 €**

VNZ 12 DT

**3.372 €**

VNZ 15 DT

**3.953 €**

VNZ 18 DT

**4.475 €**

**DT: Doble temperatura**  
Double temperature

Medidas sin costados  
Measures without sides

Fotografías no contractuales / Non contractual pictures.

Características técnicas y constructivas sujetas a variación sin previo aviso / We reserve the right to change specifications without prior notice.

Los datos técnicos están sujetos a posibles variaciones que serán actualizadas periódicamente en las fichas técnicas del producto, disponibles en la web.

The technical data are subject to possible variations that will be updated periodically in the technical data sheets of the product, which are available on the website.

www.infrico.com



485



# Vitrina expositora para pastelería

Serie  
**NIZA**  
Series

## CARACTERÍSTICAS TÉCNICAS

### Control Digital



Mayor **precisión en el sistema de control de la temperatura y humedad**. Mayor facilidad para el ajuste del intervalo de temperaturas que deseamos conseguir.

### Iluminación



Incorporación de **iluminación LED**, llegando a **reducir el consumo energético entre un 80% y 90%**. Iluminación en todos los niveles y frente para realzar los productos.

## TECHNICAL CHARACTERISTICS

### Digital control

Higher **precision in managing temperature settings**. Greater ability to adjust of temperature ranges as per the end user's requirement.

### Lighting

**LED lighting** incorporated, **reducing energetic consumption between 80% and 90%** respect to a traditional light bulb.

VNZ 12HT

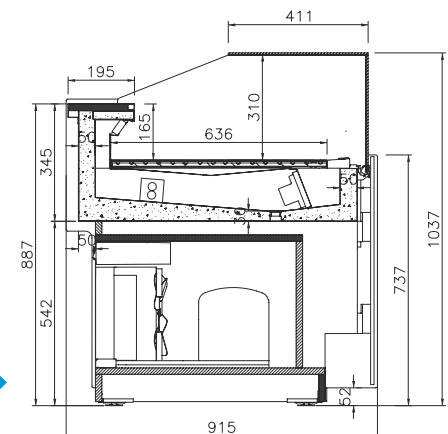

VNZ HT

MOD.	Costados Sides (mm)	Potencia Power (W)	Superficie Exposición (m <sup>2</sup> )	LED	Consumo Consumption (kWh/24h)	Desescarche Defrost	Control
VNZ9HT	20+20	380	0,60	✓	7,4	Automático Automatic	Digital
VNZ12HT	20+20	510	0,80	✓	9,9	Automático Automatic	Digital
VNZ15HT	20+20	635	1	✓	12,4	Automático Automatic	Digital
VNZ18HT	20+20	760	1,20	✓	14,8	Automático Automatic	Digital



# Pastry display case

Serie  
**NIZA**  
Series

## REFRIGERACIÓN



### Sistema calefactor

Placa caliente.

## REFRIGERATION

### Heat system

Hot plate.

VNZ 12HT + VNZ 15HT

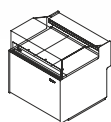

### VNZ 9 HT **2.330 €**

938 x 915 x 1040 mm.  
Temp. +40°C / +50°C  
C. Clima. 3 / 25°C  
230v/1 ph/50 Hz

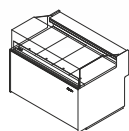

### VNZ 12 HT **2.703 €**

1250 x 915 x 1040 mm.  
Temp. +40°C / +50°C  
C. Clima. 3 / 25°C  
230v/1 ph/50 Hz

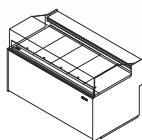

### VNZ 15 HT **3.334 €**

1562 x 915 x 1040 mm.  
Temp. +40°C / +50°C  
C. Clima. 3 / 25°C  
230v/1 ph/50 Hz

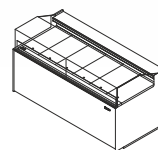

### VNZ 18 HT **3.761 €**

1875 x 915 x 1040 mm.  
Temp. +40°C / +50°C  
C. Clima. 3 / 25°C  
230v/1 ph/50 Hz

**HT: Vitrina caliente**  
Hot temperature

Medidas sin costados  
Measures without sides

Fotografías no contractuales / Non contractual pictures.

Características técnicas y constructivas sujetas a variación sin previo aviso / We reserve the right to change specifications without prior notice.

Los datos técnicos están sujetos a posibles variaciones que serán actualizadas periódicamente en las fichas técnicas del producto, disponibles en la web.

The technical data are subject to possible variations that will be updated periodically in the technical data sheets of the product, which are available on the website.

www.infrico.com



487



# Vitrina expositora para pastelería Pastry display case

Serie  
**MUEBLE-CAJA**  
Counter case Series

## CARACTERÍSTICAS TÉCNICAS



### Estructura

Exterior en **chapa plastificada.**

**Encimera** de trabajo en **Cuarzo Blanco.**

**Decoración inferior** en acero inox **AISI 304 18/10.**

Decoración y costados en **DM hidrófugo lacado.**

Decoración **frontal con iluminación LED.**

## TECHNICAL CHARACTERISTICS

### Estructure

Exterior in plastic **sheet metal.**

White compac quartz worktop.

**AISI 304** stainless steel lower part decoration.

Frontal and sides decoration in water **resistant DM lacqued.**

LED lighting **frontal decoration.**

VNZ 90 AAM



VNZ 12 M



VNZ 9 M  
**1.571 €**

938 x 915 x 740 mm.

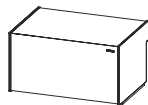

VNZ 12 M  
**1.754 €**

1250 x 915 x 740 mm.

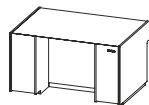

VNZ 12 MHD  
**1.880 €**

1250 x 915 x 740 mm.

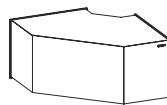

VNZ 90 AAM  
**2.541 €**

1855 x 915 x 740 mm.

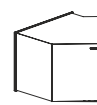

VNZ 45 AAM  
**1.410 €**

1035 x 915 x 740 mm.

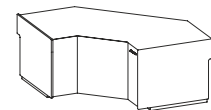

VNZ 90 ACM  
**1.849 €**

2325 x 915 x 740 mm.

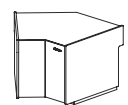

VNZ 45 ACM  
**1.436 €**

1295 x 915 x 1040 mm.

Medidas sin costados  
Measures without sides



**VNZ 12**

**RAL 5015**  
Azul / Blue



**VNZ 12**

**RAL 2003**  
Naranja / Orange

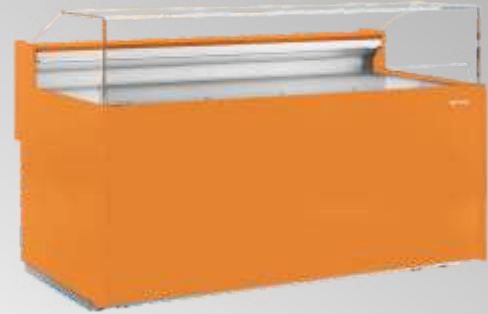

**VNZ 12**

**RAL 1018**  
Amarillo / Yellow



**VNZ 12**

**RAL DESIGN 1107060**  
Pistacho / Pistachio



**Decoración Standard / Standar Decorations**

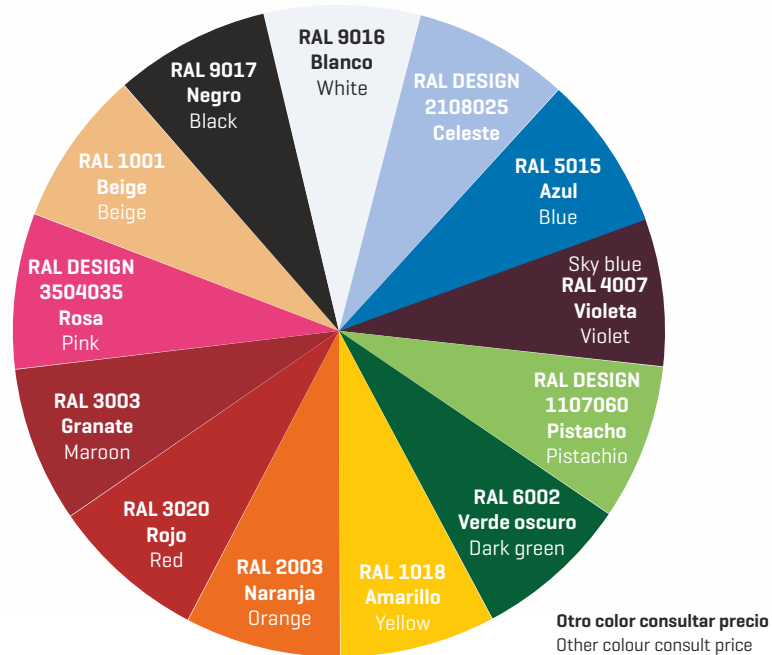

**Colores fuera de carta / Colors outside of letter**

Color	Tipo / Type	Incremento plazo de entrega / Increase delivery time	Suplemento PVP [x pedido] / PVP supplement [x order]
RAL	Epoxi	+10 días laborables / Work days	675,00 €
	Líquida / Liquid	+10 días laborables / Work days	420,00 €
NO RAL	Epoxi	Consultar / Consulter	Consultar / Consulter
	Líquida / Liquid	Consultar / Consulter	Consultar / Consulter

Fotografías no contractuales / Non contractual pictures.

Características técnicas y constructivas sujetas a variación sin previo aviso / We reserve the right to change specifications without prior notice.

Los datos técnicos están sujetos a posibles variaciones que serán actualizadas periódicamente en las fichas técnicas del producto, disponibles en la web. The technical data are subject to possible variations that will be updated periodically in the technical data sheets of the product, which are available on the website.



# Vitrina expositora para pastelería

## Pastry display case









# Vitrina expositora para pastelería

Serie  
**LYON**  
Series

## CARACTERÍSTICAS TÉCNICAS

### Control Digital



Mayor **precisión en el sistema de control de la temperatura y humedad**. Mayor facilidad para el ajuste del intervalo de temperaturas que deseamos conseguir.



### Comprobación de fuga de gas

Todos las unidades condensadoras son **comprobados al 100%, en cámara de Helio** para la detección de la fuga de gas.



### Iluminación

Incorporación de **iluminación LED**, llegando a **reducir el consumo energético entre un 80% y 90%** Iluminación en todos los niveles y frente para realzar los productos.

## TECHNICAL CHARACTERISTICS

### Digital control

Higher **precision in managing temperature settings**. Greater ability to adjust of temperature ranges as per the end user's requirement.

### Leak detection system

All condenser units are **tested 100%, in helium chambers** to refrigerant leak detections.

### Lighting

**LED lighting** incorporated, **reducing energetic consumption between 80% and 90%** respect to a traditional ligh bulb.

Estante opcional  
Optional shelf

VLY 15



VLY 15

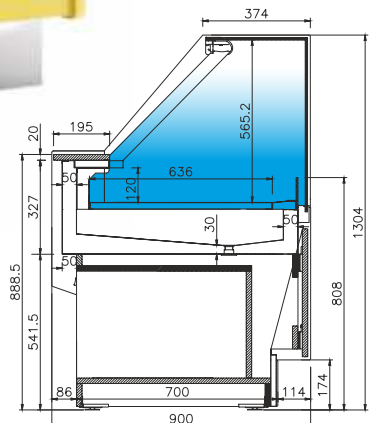

MOD.



Costados  
Sides  
(mm)



Potencia  
Power  
(W)



Bandejas  
Trays  
(300x400)



Bandejas  
Trays  
(600x400)



Superficie  
Exposición  
(m<sup>2</sup>)



Estantes  
Shelving



Compresor  
Compressor  
(HP)



Consumo  
Consumption  
(kWh/24h)



Potencia  
frigorífica  
Cooling capacity  
(W a -10°C)



Control



Refrigerante  
Coolant

MOD.	Costados Sides (mm)	Potencia Power (W)	Bandejas Trays (300x400)	Bandejas Trays (600x400)	Superficie Exposición (m <sup>2</sup> )	Estantes Shelving	Compresor Compressor (HP)	Consumo Consumption (kWh/24h)	Potencia frigorífica Cooling capacity (W a -10°C)	Control	Refrigerante Coolant
VLY9	30+30	750	4	2	0,60	1 OPC.	1/4	5,8	298	Digital	R-134a
VLY12	30+30	795	6	3	0,80	1 OPC.	1/3	7	395	Digital	R-134a
VLY15	30+30	870	6	3	1,00	1 OPC.	3/8	8,2	464	Digital	R-134a
VLY18	30+30	920	8	4	1,20	1 OPC.	1/2	9,3	568	Digital	R-134a
VLY25	30+30	1010	12	6	1,60	1 OPC.	5/8	11,2	684	Digital	R-134a



# Pastry display case

Serie  
**LYON**  
Series

## REFRIGERACIÓN



### Refrigeración

Sistema de **Condensación Ventilada**.  
**Desescarche** automático.  
Bandeja **evaporativa** automática.

## REFRIGERATION

### Refrigeration system

System of **Ventilated Condensation**.  
Automatic **defrost**.  
Automatic **evaporative** tray.

VLY 9



### MOD.

Puertas correderas traseras  
Rear sliding doors

VLY 9	[PUEVLY9CT]	<b>146 €</b>
VLY 12	[PUEVLY12CT]	<b>193 €</b>
VLY 15	[PUEVLY15CT]	<b>200 €</b>

### MOD.

Puertas correderas traseras  
Rear sliding doors

VLY 18	[PUEVLY18CT]	<b>208 €</b>
VLY 25	[PUEVLY25CT]	<b>215 €</b>

### MOD.

Estante  
Shelf

VLY 9	[ESTVCB9]	<b>156 €</b>
VLY 12	[ESTVCB12]	<b>176 €</b>
VLY 15	[ESTVCB15]	<b>197 €</b>
VLY 18	[ESTVCB18]	<b>275 €</b>
VLY 25	[ESTVCB25]	<b>314 €</b>



**VLY 9**  
**2.807 €**

938 x 900 x 1305 mm.  
Temp. +4°C / +8°C  
C. Clima. 3 / 25°C  
230v/1ph/50 Hz

Medidas sin costados  
Measures without sides



**VLY 12**  
**3.177 €**

1250 x 900 x 1305 mm.  
Temp. +4°C / +8°C  
C. Clima. 3 / 25°C  
230v/1ph/50 Hz

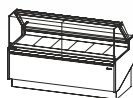

**VLY 15**  
**3.647 €**

1562 x 900 x 1305 mm.  
Temp. +4°C / +8°C  
C. Clima. 3 / 25°C  
230v/1ph/50 Hz

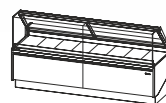

**VLY 18**  
**4.111 €**

1875 x 900 x 1305 mm.  
Temp. +4°C / +8°C  
C. Clima. 3 / 25°C  
230v/1ph/50 Hz

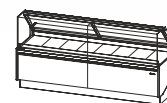

**VLY 25**  
**4.793 €**

1250 x 900 x 1305 mm.  
Temp. +4°C / +8°C  
C. Clima. 3 / 25°C  
230v/1ph/50 Hz

Fotografías no contractuales / Non contractual pictures.

Características técnicas y constructivas sujetas a variación sin previo aviso / We reserve the right to change specifications without prior notice.

Los datos técnicos están sujetos a posibles variaciones que serán actualizadas periódicamente en las fichas técnicas del producto, disponibles en la web.  
The technical data are subject to possible variations that will be updated periodically in the technical data sheets of the product, which are available on the website.

www.infrico.com



493



# Vitrina expositora para pastelería

Serie  
**LYON**  
**VIENNOISERIE**  
Series

## CARACTERÍSTICAS TÉCNICAS

### Estructura

Línea Modular. Alta capacidad y amplio plano de exposición. Ángulos y mostradores para adaptar la línea a un espacio determinado.



## TECHNICAL CHARACTERISTICS

### Estructure

Modular Line Designed for pastry, pastries, and bakery. High capacity and wide exposure plane. Angles and counters to adapt the line to a specific space.

**VLY 9 V**

**Módulo Neutro**  
Neutral module



**MOD.**



Costados  
Sides  
(mm)



Potencia  
Power  
(W)



Bandejas  
Trays  
(300x400)



Bandejas  
Trays  
(600x400)



Superficie  
Exposición  
(m<sup>2</sup>)



Estantes  
Shelving



Consumo  
Consumption  
(kWh/24h)

MOD.	Costados Sides (mm)	Potencia Power (W)	Bandejas Trays (300x400)	Bandejas Trays (600x400)	Superficie Exposición (m <sup>2</sup> )	Estantes Shelving	Consumo Consumption (kWh/24h)
VLY9 V	30+30	45	12	8	1,13	3	0,6
VLY12 V	30+30	70	16	12	1,50	3	1



# Pastry display case

Serie  
**LYON**  
**VIENNOISERIE**  
Series

## CARACTERÍSTICAS TÉCNICAS



### Estructura

**Encimera** de trabajo en **compac quartz** blanco.

**Cristal** recto **segurizado**.

**Decoración** y **costado** en **DM hidrófugo** lacado.

Decoración frontal con **iluminación LED**.

**Iluminación LED** plano de exposición.

**Iluminación LED** estantes.

**Estantes** en perfil de **aluminio anodizado**.

## TECHNICAL CHARACTERISTICS

### Estructure

White **compac quartz** worktop.

**Flat front security**.

Frontal and sides decoration in water **resistant DM lacqued**.

**LED lighting** frontal decoration.

Exhibition area **LED lighting**.

Shelf **LED lighting**.

**Shelves in anodized aluminum** profile.

VLY 12 V



### Puertas correderas traseras de serie

Rear sliding doors standard



VLY 9V

**3.064 €**

938 x 900 x 1550 mm.

Medidas sin costados  
Measures without sides



VLY 12V

**3.500 €**

1250 x 900 x 1550 mm.

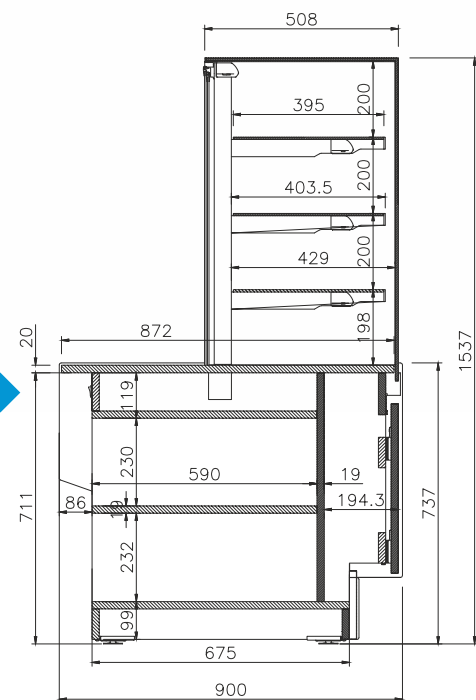



# Vitrina expositora para pastelería Pastry display case

Serie  
**LYON**  
**CHOCOLATE**  
Series

## REFRIGERACIÓN



### Refrigeración

Sistema de **Condensación Ventilada**.  
**Desescarche** automático.  
Bandeja **evaporativa** automática.

## REFRIGERATION

### Refrigeration system

System of **Ventilated Condensation**.  
Automatic **defrost**.  
Automatic **evaporative** tray.

Vitrina LYON para venta de chocolates  
LYON display case for chocolate sale



VLY 12 B



VLY 12 B

**3.236 €**

1250 x 900 x 1060 mm.  
Temp. +7°C / +12°C  
C. Clima. 3 / 25°C  
230v/1ph/50 Hz

Medidas sin costados  
Measures without sides

### Opcional / Optional

Puertas correderas traseras  
Rear sliding doors

VLY 12 B (PUEVLY12CTB) 186 € **190 €**

VLY B

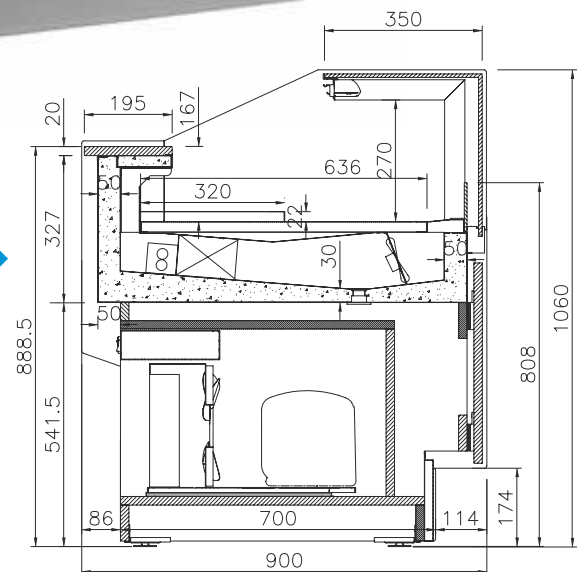

MOD.



Costados  
Sides  
(mm)



Potencia  
Power  
(W)



Capacidad  
Capacity  
(L)



Superficie  
Exposición  
(m<sup>2</sup>)



Compresor  
Compressor  
(HP)



LED



Consumo  
Consumption  
(kWh/24h)



Potencia frigorífica  
Cooling capacity  
(W a -10°C)



Control



Refrigerante  
Coolant

VLY 12 B	30+30	795	6	0,80	1/5	✓	6,1	254	Digital	R-134a
----------	-------	-----	---	------	-----	---	-----	-----	---------	--------





# Vitrina expositora para pastelería Pastry display case

Serie  
**LYON**  
**BAIN MARIE**  
Series

## REFRIGERACIÓN

### Refrigeración



Sistema de **calentamiento** indirecto por resistencias ocultas.

La regulación y **control de la temperatura** del baño María se realiza mediante un **control digital**, con una temperatura de trabajo de +60°C a +70°C.

## REFRIGERATION

### Refrigeration system

Indirect **heating system** by **hidden resistors**.

The regulation and **control of the temperature** of the water bath is carried out by means of a **digital control**, with a working temperature of +60°C to +70°C.

Vitrina LYON Baño María para servicio de comida caliente  
LYON display case Bain Marie for food service

VLY 12 BMS



VLY 12 BMS  
**3.482 €**

1250 x 900 x 1305 mm.  
Temp. +60°C / +70°C

Medidas sin costados  
Measures without sides



VLY 15 BMS  
**3.984 €**

1250 x 900 x 1305 mm.  
Temp. +60°C / +70°C

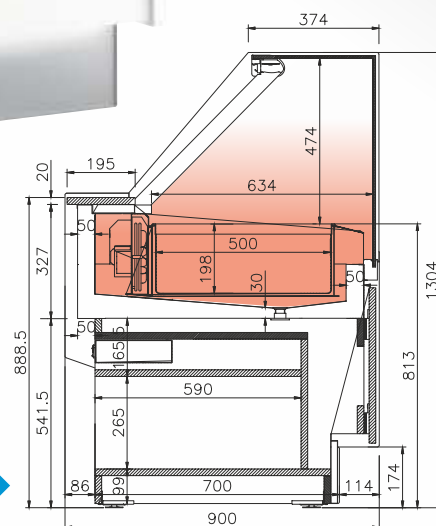

VLY

MOD.



Costados  
Sides  
(mm)



Potencia  
Power  
(W)



Bandejas  
Trays  
(600x400)



Superficie  
Exposición  
(m<sup>2</sup>)



LED



Consumo  
Consumption  
(kWh/24h)



Control

MOD.	Costados Sides (mm)	Potencia Power (W)	Bandejas Trays (600x400)	Superficie Exposición (m <sup>2</sup> )	LED	Consumo Consumption (kWh/24h)	Control
VLY12BMS	30+30	2050	3	0,69	✓	12,3	Digital
VLY15BMS	30+30	3050	4	0,86	✓	18,3	Digital

Fotografías no contractuales / Non contractual pictures.

Características técnicas y constructivas sujetas a variación sin previo aviso / We reserve the right to change specifications without prior notice.

Los datos técnicos están sujetos a posibles variaciones que serán actualizadas periódicamente en las fichas técnicas del producto, disponibles en la web.

The technical data are subject to possible variations that will be updated periodically in the technical data sheets of the product, which are available on the website.





# Vitrina expositora para pastelería vidrio bajo Pastry display case low case



Serie  
**LYON LG**  
Series







# Vitrina expositora para pastelería vidrio bajo

Serie  
**LYON LG**  
Series

## CARACTERÍSTICAS TÉCNICAS



### Comprobación de fuga de gas

Todos los circuitos frigoríficos son **comprobados al 100%, en cámara de Helio** para la detección de la fuga de gas.

## TECHNICAL CHARACTERISTICS

### Leak detection system

All the condensing units are **100% tested, in a Helium chamber** for the detection of gas leakage.

VLY 15 LG



MOD.



Costados  
Sides  
(mm)



Potencia  
Power  
(W)



Bandejas  
Trays  
(300x400)



Bandejas  
Trays  
(600x400)



Superficie  
Exposición  
(m<sup>2</sup>)



Compresor  
Compressor  
(HP)



LED



Consumo  
Consumption  
(kWh/24h)



Potencia  
frigorífica  
Cooling capacity  
(W a -10°C)



Control



Refrigerante  
Coolant

MOD.	Costados Sides (mm)	Potencia Power (W)	Bandejas Trays (300x400)	Bandejas Trays (600x400)	Superficie Exposición (m <sup>2</sup> )	Compresor Compressor (HP)	LED	Consumo Consumption (kWh/24h)	Potencia frigorífica Cooling capacity (W a -10°C)	Control	Refrigerante Coolant
VLY9 LG	30+30	750	4	2	0,60	1/4	✓	5,8	298	Digital	R-134a
VLY12 LG	30+30	795	6	3	0,80	1/3	✓	7	395	Digital	R-134a
VLY15 LG	30+30	870	6	3	1,00	3/8	✓	8,2	464	Digital	R-134a
VLY18 LG	30+30	920	8	4	1,20	1/2	✓	9,3	568	Digital	R-134a
VLY25 LG	30+30	1010	12	6	1,60	5/8	✓	11,2	684	Digital	R-134a

Fotografías no contractuales / Non contractual pictures.

Características técnicas y constructivas sujetas a variación sin previo aviso / We reserve the right to change specifications without prior notice.

Los datos técnicos están sujetos a posibles variaciones que serán actualizadas periódicamente en las fichas técnicas del producto, disponibles en la web.  
The technical data are subject to possible variations that will be updated periodically in the technical data sheets of the product, which are available on the website.



# Pastry display case low case

Serie  
**LYON LG**  
Series

## REFRIGERACIÓN



### Refrigeración

Sistema de **Condensación Ventilada**.

**Desescarche** automático.

Bandeja **evaporativa** automática.

## REFRIGERATION

### Refrigeration system

System of **Ventilated Condensation**.

Automatic **defrost**.

Automatic **evaporative** tray.

VLY 12 LG

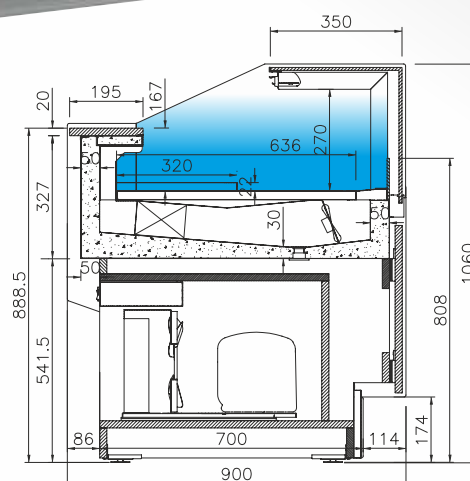

VLY LG



**VLY 9 LG**  
**2.768 €**

938 x 900 x 1060 mm.  
Temp. +4°C / +8°C  
C. Clima. 3 / 25°C  
230v/1ph/50 Hz



**VLY 12 LG**  
**3.125 €**

1250 x 900 x 1060 mm.  
Temp. +4°C / +8°C  
C. Clima. 3 / 25°C  
230v/1ph/50 Hz



**VLY 15 LG**  
**3.576 €**

1562 x 900 x 1060 mm.  
Temp. +4°C / +8°C  
C. Clima. 3 / 25°C  
230v/1ph/50 Hz



**VLY 18 LG**  
**4.111 €**

1875 x 900 x 1060 mm.  
Temp. +4°C / +8°C  
C. Clima. 3 / 25°C  
230v/1ph/50 Hz



**VLY 25 LG**  
**4.698 €**

2500 x 900 x 1060 mm.  
Temp. +4°C / +8°C  
C. Clima. 3 / 25°C  
230v/1ph/50 Hz

Medidas sin costados  
Measures without sides

Fotografías no contractuales / Non contractual pictures.

Características técnicas y constructivas sujetas a variación sin previo aviso / We reserve the right to change specifications without prior notice.

Los datos técnicos están sujetos a posibles variaciones que serán actualizadas periódicamente en las fichas técnicas del producto, disponibles en la web.

The technical data are subject to possible variations that will be updated periodically in the technical data sheets of the product, which are available on the website.

www.infrico.com



501



# Mueble caja

## Counter case

Serie

# MUEBLE CAJA

## Counter Case Series

### CARACTERÍSTICAS TÉCNICAS

#### Estructura

**Encimera** de trabajo en **compac quartz** blanco.

**Decoración** en **DM hidrófugo** lacado.

Decoración frontal con **iluminación LED**.



### TECHNICAL CHARACTERISTICS

#### Estructure

White **compac quartz** worktop.

Frontal decoration in water **resistant DM lacqued**.

**LED lighting** frontal decoration.

VLY 9 M



VLY 12 MHD

HANDICAPÉ

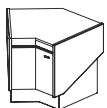

VLY 45 ACM

**1.842 €**

1295 x 900 x 745 mm.

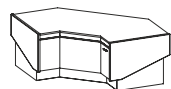

VLY 90 ACM

**2.561 €**

2325 x 900 x 745 mm.



VLY 9 M

**1.612 €**

938 x 900 x 745 mm.

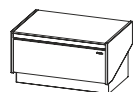

VLY 12 M

**1.825 €**

1250 x 900 x 745 mm.

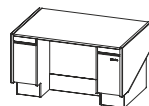

VLY 12 MHD

**2.010 €**

1250 x 900 x 745 mm.



VLY 45 AAM

**1.578 €**

1035 x 900 x 745 mm.



VLY 90 AAM

**1.936 €**

1855 x 900 x 745 mm.

Medidas sin costados  
Measures without sides





## Decoración Standard / Standar Decorations

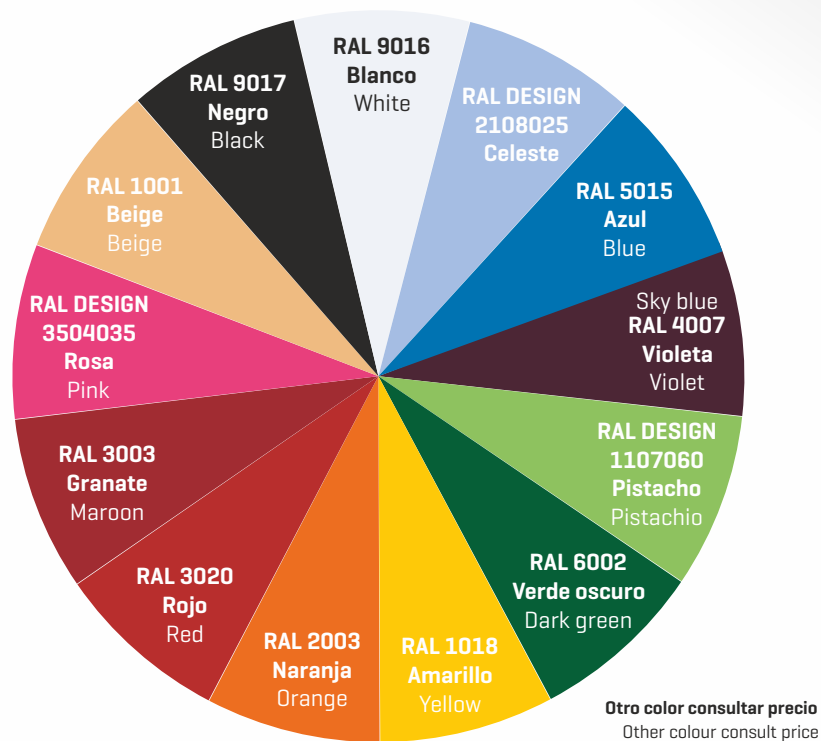

## Colores fuera de carta / Colors outside of letter

Color	Tipo Type	Incremento plazo de entrega Increase delivery time	Suplemento PVP [x pedido] PVP supplement [x order]
RAL	Epoxi	+10 días laborables/ Work days	675,00 €
	Líquida/Liquid	+10 días laborables/ Work days	420,00 €
NO RAL	Epoxi	Consultar/Consulter	Consultar/Consulter
	Líquida/Liquid	Consultar/Consulter	Consultar/Consulter



# Vitrina expositora para pastelería

## Pastry display case



Serie  
**AMBAR**  
Series





# Vitrina expositora para pastelería

Serie  
**AMBAR**  
Series

## CARACTERÍSTICAS TÉCNICAS



### Comprobación de fuga de gas

Todos los circuitos frigoríficos son **comprobados al 100%, en cámara de Helio** para la detección de la fuga de gas.

## TECHNICAL CHARACTERISTICS

### Leak detection system

All the condensing units are **100% tested, in a Helium chamber** for the detection of gas leakage.

VBR 12 R



MOD.	Costados Sides (mm)	Potencia Power (W)	Capacidad Capacity (L)	Nº puertas Doors	Superficie Exposición (m <sup>2</sup> )	Estantes Shelving	Compresor Compressor (HP)	Consumo Consumption (kWh/24h)	Evaporación Evaporation	Potencia frigorífica Cooling capacity (W a -10°C)	Control	Refrigerante Coolant
VBR 9 R	20+20	1000	274	2	1,4	3	1/2	16,0	+4°C/+8°C	1096	Digital	R-452
VBR 12 R	20+20	1060	365	2	1,9	3	3/4	17,0	+4°C/+8°C	1315	Digital	R-452
VBR 18 R	20+20	1340	548	3	2,8	3	1	21,4	+4°C/+8°C	1840	Digital	R-452



# Pastry display case

Serie  
**AMBAR**  
Series

## REFRIGERACIÓN



### Refrigeración

Sistema de **Condensación Ventilada**.  
Bandeja **evaporativa** doble.

## REFRIGERATION

### Refrigeration system

System of **Ventilated Condensation**.  
Double **evaporative** tray.

**VBR 12 R**



**VBR 9 R**

**RAL 3001**  
Rojo / Red



**VBR 9 R**  
**3.533 €**

938 x 810 x 1300 mm.  
Temp. +4°C / +8°C  
C. Clima. 4 / 38°C  
230v/1ph/50 Hz



**VBR 12 R**  
**3.900 €**

1250 x 810 x 1300 mm.  
C. Clima. 4 / 38°C  
Temp. +4°C / +8°C  
230v/1ph/50 Hz



**VBR 18 R**  
**4.946 €**

1875 x 810 x 1300 mm.  
C. Clima. 4 / 38°C  
Temp. +4°C / +8°C  
230v/1ph/50 Hz

### Opcional / Optional

Cristal frontal doble /  
Double front glass

VBR 9 **221 € \***

VBR 12 **243 € \***

VBR 18 **444 € \***

\* Este precio es aplicable cuando el cristal va incorporado en el mueble.

\* This price is applicable when the glass is incorporated with the display case.

**VBR R**

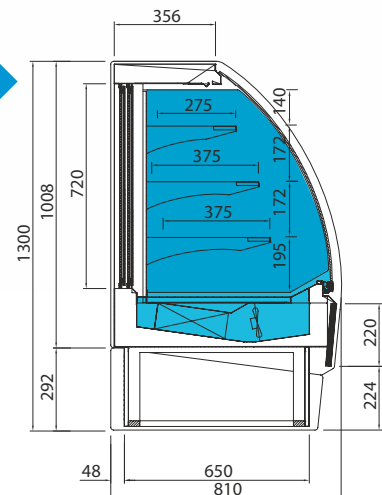

Medidas sin costados  
Measures without sides

Fotografías no contractuales / Non contractual pictures.

Características técnicas y constructivas sujetas a variación sin previo aviso / We reserve the right to change specifications without prior notice.

Los datos técnicos están sujetos a posibles variaciones que serán actualizadas periódicamente en las fichas técnicas del producto, disponibles en la web.

The technical data are subject to possible variations that will be updated periodically in the technical data sheets of the product, which are available on the website.

www.infrico.com



507





# Vitrina caliente expositora para pastelería

Serie  
**AMBAR**  
Series

## CARACTERÍSTICAS TÉCNICAS

### Control



Mayor precisión en el sistema de control de la temperatura y humedad. Mayor facilidad para el ajuste del intervalo de temperaturas que deseamos conseguir.



### Comprobación de fuga de gas

Todos los circuitos frigoríficos son **comprobados al 100%, en cámara de Helio** para la detección de la fuga de gas.



### Iluminación

Incorporación de **iluminación LED**, llegando a **reducir** el consumo energético **entre un 80% y 90%**.

## TECHNICAL CHARACTERISTICS

### Control

Higher precision in managing temperature settings. Greater ability to adjust of temperature ranges as per the end user's requirement.

### Leak detection system

All the condensing units are **100% tested, in a Helium chamber** for the detection of gas leakage.

### Lighting

**LED lighting** incorporated, **reducing** energetic consumption **between 80% and 90%**.

VBR 12 HT



### MOD.



Costados  
Sides  
(mm)



Potencia  
Power  
(W)



Capacidad  
Capacity  
(L)



Nº puertas  
Doors



Superficie  
Exposición  
(m<sup>2</sup>)



Estantes  
Shelving



Consumo  
Consumption  
(kWh/24h)



Control

MOD.	Costados Sides (mm)	Potencia Power (W)	Capacidad Capacity (L)	Nº puertas Doors	Superficie Exposición (m <sup>2</sup> )	Estantes Shelving	Consumo Consumption (kWh/24h)	Control
VBR 9 HT	20+20	570	274	2	1	2	6,8	Digital
VBR 12 HT	20+20	830	365	2	1,4	2	10,0	Digital
VBR 18 HT	20+20	1100	548	3	2,1	2	13,2	Digital



# Pastry hot display case

Serie  
**AMBAR**  
Series

## REFRIGERACIÓN



### Sistema calefactor

Resistencia **blindada y aleteada**.  
Bandeja en el interior para **aportar humedad**.

**Termostato electrónico** trasero.

**Display temperatura** interno.

## REFRIGERATION

### Refrigeration system

**Reinforced** resistance and **finned**.

Internal tray to **supply humidity**.

**Electronic** thermostat.

Internal **temperatura display**.

VBR 12 HT



VBR HT

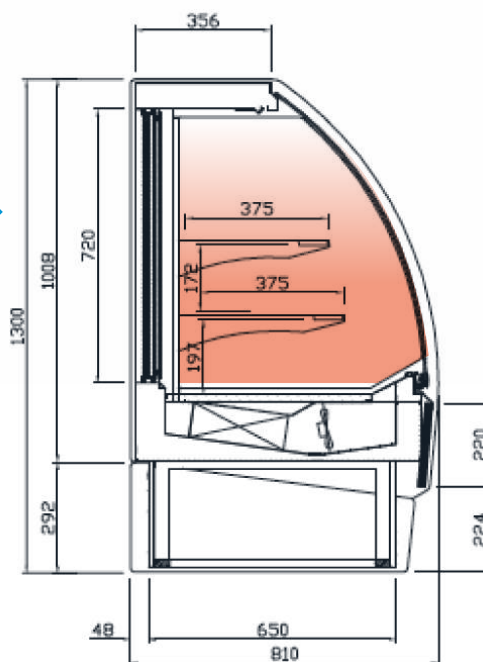

VBR 9 HT  
**3.160 €**

938 x 810 x 1300 mm.  
Temp. +55°C / +60°C



VBR 12 HT  
**3.482 €**

1250 x 810 x 1300 mm.  
Temp. +55°C / +60°C



VBR 18 HT  
**4.420 €**

1875 x 810 x 1300 mm.  
Temp. +55°C / +60°C

Medidas sin costados  
Measures without sides

Fotografías no contractuales / Non contractual pictures.

Características técnicas y constructivas sujetas a variación sin previo aviso / We reserve the right to change specifications without prior notice.

Los datos técnicos están sujetos a posibles variaciones que serán actualizadas periódicamente en las fichas técnicas del producto, disponibles en la web.

The technical data are subject to possible variations that will be updated periodically in the technical data sheets of the product, which are available on the website.

www.infrico.com



509



# Vitrina expositora para pastelería autoservicio

Serie  
**AMBAR**  
Series

## CARACTERÍSTICAS TÉCNICAS

## TECHNICAL CHARACTERISTICS



### Comprobación de fuga de gas

Todos los circuitos frigoríficos son **comprobados al 100%, en cámara de Helio** para la detección de la fuga de gas.

### Leak detection system

All the condensing units are **100% tested, in a Helium chamber** for the detection of gas leakage.

VBR 12 SS



**Cortina nocturna**  
Nigth curtain

MOD.

MOD.	Costados Sides (mm)	Potencia Power (W)	Capacidad Capacity (L)	Nº puertas Doors	Superficie Exposición (m <sup>2</sup> )	Estantes Shelving	Compresor Compressor (HP)	Consumo Consumption (kWh/24h)	Régimen TRA (25°C)	Potencia frigorífica Cooling capacity (W a -10°C)	Control	Refrigerante Coolant	De serie Standard
------	---------------------	--------------------	------------------------	------------------	---	-------------------	---------------------------	-------------------------------	--------------------	---	---------	----------------------	-------------------

VBR 6 SS	20+20	825	180	-	0,9	3	1/3	18,2	+4°C/+8°C	750	Digital	R-452	Corina nocturna Nigth curtain
VBR 9 SS	20+20	1000	274	-	1,4	3	1/2	20,0	+4°C/+8°C	890	Digital	R-452	Corina nocturna Nigth curtain
VBR 12 SS	20+20	1060	365	-	1,9	3	3/4	21,2	+4°C/+8°C	1315	Digital	R-452	Corina nocturna Nigth curtain
VBR 18 SS	20+20	1340	548	-	2,8	3	1	26,8	+4°C/+8°C	1840	Digital	R-452	Corina nocturna Nigth curtain



# Self service pastry display case

Serie  
**AMBAR**  
Series

## REFRIGERACIÓN



### Refrigeración

Sistema de **Condensación Ventilada**.  
Bandeja **evaporativa** doble.

## REFRIGERATION

### Refrigeration system

System of **Ventilated Condensation**.  
Double **evaporative** tray.

VBR 6 SS



VBR SS



**VBR 6 SS**  
**3.138 €**

625 x 810 x 1300 mm.  
C. Clima. 3 / 25°C  
230v/1ph/50 Hz



**VBR 9 SS**  
**3.460 €**

938 x 810 x 1300 mm.  
C. Clima. 3 / 25°C  
230v/1ph/50 Hz



**VBR 12 SS**  
**3.862 €**

1250 x 810 x 1300 mm.  
C. Clima. 3 / 25°C  
230v/1ph/50 Hz

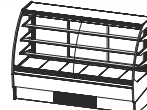

**VBR 18 SS**  
**4.883 €**

1875 x 810 x 1300 mm.  
C. Clima. 3 / 25°C  
230v/1ph/50 Hz

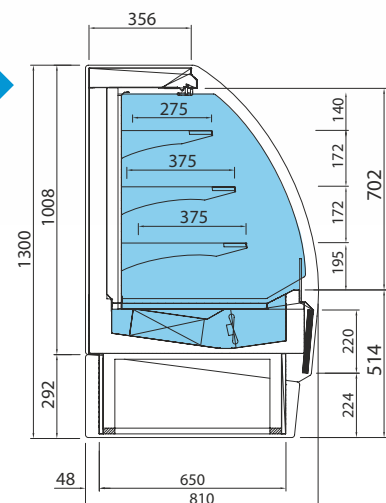

Medidas sin costados  
Measures without sides

Fotografías no contractuales / Non contractual pictures.

Características técnicas y constructivas sujetas a variación sin previo aviso / We reserve the right to change specifications without prior notice.

Los datos técnicos están sujetos a posibles variaciones que serán actualizadas periódicamente en las fichas técnicas del producto, disponibles en la web.

The technical data are subject to possible variations that will be updated periodically in the technical data sheets of the product, which are available on the website.

www.infrico.com



511



# Vitrina expositora para pastelería de doble servicio

## Double service pastry display case

Serie  
**AMBAR**  
Series

### CARACTERÍSTICAS TÉCNICAS

### TECHNICAL CHARACTERISTICS



#### Refrigeración

Sistema de **Condensación Ventilada**.  
Bandeja **evaporativa** doble.

#### Refrigeration system

System of **Ventilated Condensation**.  
Double **evaporative** tray.

**VBR 12 DS**



**Doble acceso**  
Double access



**VBR 9 DS**  
**3.652 €**

938 x 810 x 1300 mm.  
Temp. +4°C / +8°C  
C. Clima. 3 / 25°C  
230v/1ph/50 Hz



**VBR 12 DS**  
**4.075 €**

1250 x 810 x 1300 mm.  
Temp. +4°C / +8°C  
C. Clima. 3 / 25°C  
230v/1ph/50 Hz

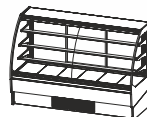

**VBR 18 DS**  
**6.360 €**

1875 x 810 x 1300 mm.  
Temp. +4°C / +8°C  
C. Clima. 3 / 25°C  
230v/1ph/50 Hz

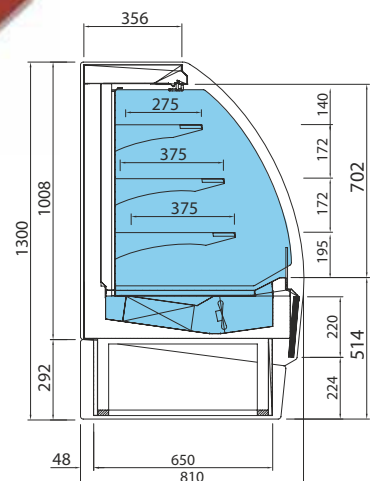

**VBR DS**

Medidas sin costados  
Measures without sides

MOD.	Costados Sides (mm)	Potencia Power (W)	Capacidad Capacity (L)	Nº puertas Doors	Superficie Exposición (m <sup>2</sup> )	Estantes Shelving	Compresor Compressor (HP)	LED	Consumo Consumption (kWh/24h)	Evaporación Evaporation	Potencia frigorífica Cooling capacity (W a -10°C)	Desescarche Defrost	Control	Refrigerante Coolant	De serie Standard
VBR 9 DS	20+20	1000	274	2	1,4	3	1/2	✓	20,0	Forzada Forced	1096	Automático Automatic	Digital	R-452	Corina nocturna Night curtain
VBR 12 DS	20+20	1060	365	2	1,9	3	3/4	✓	21,2	Forzada Forced	1315	Automático Automatic	Digital	R-452	Corina nocturna Night curtain
VBR 18 DS	20+20	1640	548	4	2,8	3	1/2+1/2	✓	36,8	Forzada Forced	2192	Automático Automatic	Digital	R-452	Corina nocturna Night curtain





**VBR DS**

**RAL 9016**  
Blanco / White



**VBR DS**

**RAL 3020**  
Rojo / Red



**VBR DS**

**RAL 2003**  
Naranja / Orange



**VBR DS**

**RAL 5015**  
Azul / Blue



**VBR DS**

**RAL DESIGN 2108025**  
Celeste / Sky blue



**VBR DS**

**RAL DESIGN 1107060**  
Pistacho / Pistachio



## Decoración Standard / Standar Decorations

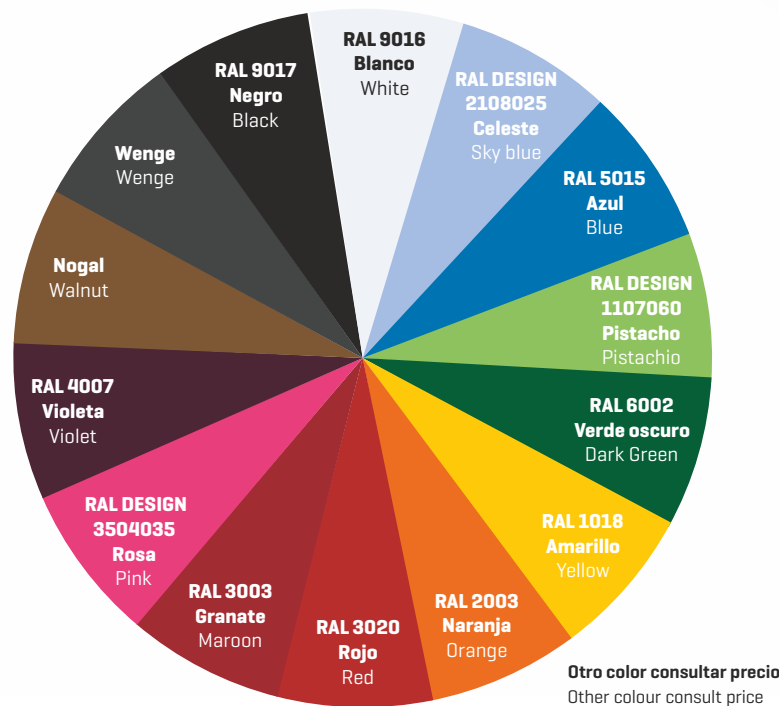

## Colores fuera de carta / Colors outside of letter

Color	Tipo Type	Incremento plazo de entrega Increase delivery time	Suplemento PVP (x pedido) PVP supplement (x order)
RAL	Epoxi	+10 días laborables/ Work days	675,00 €
	Líquida/Liquid	+10 días laborables/ Work days	420,00 €
NO RAL	Epoxi	Consultar/Consulter	Consultar/Consulter
	Líquida/Liquid	Consultar/Consulter	Consultar/Consulter





# Vitrina expositora para pastelería Pastry display case



Serie  
**AMBAR RECTA**  
Series



V. PASTERERIA  
PASTRY DISPLAY CASES





# Vitrina expositora para pastelería y panadería

Serie  
**AMBAR MUFFIN**  
Series

## CARACTERÍSTICAS TÉCNICAS



### Modular

Diseñada para pastelería y panadería. Colores estándar y posibilidad de paneles decorativos de fácil colocación.



### Control

Mayor precisión en el sistema de control de la temperatura y humedad. Mayor facilidad para el ajuste del intervalo de temperaturas que deseamos conseguir.



### Iluminación

Incorporación de **iluminación LED**, llegando a **reducir** el consumo energético **entre un 80% y 90%**.

## TECHNICAL CHARACTERISTICS

### Modular

Designed for pastry, Viennese breads and bakery. Apart from standard colours, customers can easily collocate other decorative panels.

### Control

Higher precision in managing temperature settings. Greater ability to adjust of temperature ranges as per the end user's requirement.

### Lighting

**LED lighting** incorporated, **reducing** energetic consumption **between 80% and 90%**.

VBR 6 SL



NOVEDAD  
NEW

Apertura Derecha / Right Opening

VBR 12 NVR

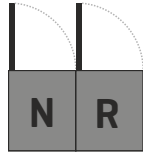

N=Neutro / Neutral  
R=Refrigerado / Refrigerated

Apertura Izquierda / Left Opening

VBR 12 VNL

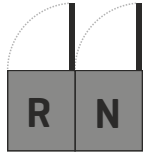

Apertura Derecha / Right Opening

VBR 6 SR  
VBR 6 VR



Apertura Izquierda / Left Opening

VBR 6 SL  
VBR 6 VL



R=Refrigerado / Refrigerated

Modelos VR/VL = Cristal frontal  
Modelos SL/SR = Self-service



Sistema Ventilación  
Ventilation system



Sistema anticondensación  
Anti-condensation System

MOD.



Potencia Power (W)



Capacidad Capacity (L)



Nº puertas Doors



Estantes Shelving



Compresor Compressor (HP)



Consumo Consumption (kWh/24h)



Potencia frigorífica Cooling capacity (W a -10°C)



Control



Refrigerante Coolant

MOD.	Potencia Power (W)	Capacidad Capacity (L)	Nº puertas Doors	Estantes Shelving	Compresor Compressor (HP)	Consumo Consumption (kWh/24h)	Potencia frigorífica Cooling capacity (W a -10°C)	Control	Refrigerante Coolant
VBR 12 NVR	1325	364	2	6	1/2	21,19	1096	Digital	R-452
VBR 12 VNL	1325	364	2	6	1/2	21,19	1096	Digital	R-452
VBR 6 SL	840	182	1	3	1/2	13,44	1096	Digital	R-452
VBR 6 SR	840	182	1	3	1/2	13,44	1096	Digital	R-452
VBR 6 VR	840	182	1	3	1/2	13,44	1096	Digital	R-452
VBR 6 VL	840	182	1	3	1/2	13,44	1096	Digital	R-452

11

Fotografías no contractuales / Non contractual pictures.

Características técnicas y constructivas sujetas a variación sin previo aviso / We reserve the right to change specifications without prior notice.

Los datos técnicos están sujetos a posibles variaciones que serán actualizadas periódicamente en las fichas técnicas del producto, disponibles en la web. The technical data are subject to possible variations that will be updated periodically in the technical data sheets of the product, which are available on the website.



# Pastry and bakery display case

Serie  
**AMBAR MUFFIN**  
Series

## REFRIGERACIÓN



### Refrigeración

Temperatura y descongelación regulada por control digital.  
Descongelación por gas caliente.  
Sistema de **Condensación Ventilada**.

## REFRIGERATION

### Refrigeration system

Temperature and defrost regulated by a digital controller.  
Defrost by hot gas.  
System of **Ventilated Condensation**.

VBR 6 SR



**Puerta batiente**  
Swing door



**Plexiglass para autoservicio**  
Low Plexiglass self-service



**Manguera desagüe, sin bandeja evaporativa [modelos VR6/VR/VL/SR/SL]**  
Drain hose, without evaporative tray [models VR6/VR/VL/SR/SL]



NOVEDAD  
NEW

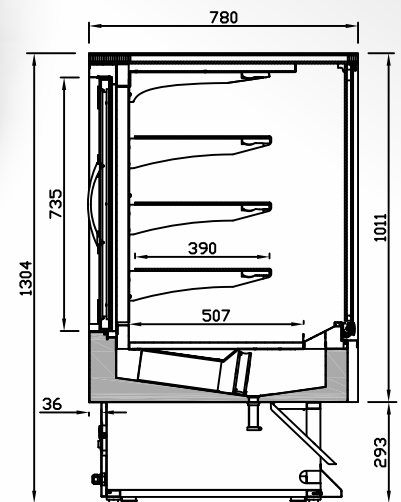

VBR 6 VNL



**VBR 12 NVR**  
**9.038 €**

1340 x 780 x 1408 mm.  
Temp. +4°C / +6°C  
C. Clima. 3 / 25°C  
230v/1ph/50 Hz



**VBR 12 VNL**  
**9.038 €**

1340 x 780 x 1408 mm.  
Temp. +4°C / +6°C  
C. Clima. 3 / 25°C  
230v/1ph/50 Hz



**VBR 6 SL**  
**4.860 €**

685 x 780 x 1408 mm.  
Temp. 0°C / +3°C  
C. Clima. 3 / 25°C  
230v/1ph/50 Hz



**VBR 6 SR**  
**4.860 €**

685 x 780 x 1408 mm.  
Temp. 0°C / +3°C  
C. Clima. 3 / 25°C  
230v/1ph/50 Hz



**VBR 6 VL**  
**4.966 €**

685 x 780 x 1408 mm.  
Temp. 0°C / +3°C  
C. Clima. 3 / 25°C  
230v/1ph/50 Hz



**VBR 6 VR**  
**4.966 €**

685 x 780 x 1408 mm.  
Temp. 0°C / +3°C  
C. Clima. 3 / 25°C  
230v/1ph/50 Hz





# Vitrina expositora para pastelería

Serie  
**AMBAR RECTA**  
Series

## CARACTERÍSTICAS TÉCNICAS

### Control



Mayor precisión en el sistema de control de la temperatura y humedad. Mayor facilidad para el ajuste del intervalo de temperaturas que deseamos conseguir.



### Comprobación de fuga de gas

Todos los circuitos frigoríficos son **comprobados al 100%, en cámara de Helio** para la detección de la fuga de gas.



### Iluminación

Incorporación de **iluminación LED**, llegando a **reducir** el consumo energético **entre un 80% y 90%**.

## TECHNICAL CHARACTERISTICS

### Control

Higher precision in managing temperature settings. Greater ability to adjust of temperature ranges as per the end user's requirement.

### Leak detection system

All the condensing units are **100% tested, in a Helium chamber** for the detection of gas leakage.

### Lighting

**LED lighting** incorporated, **reducing** energetic consumption **between 80% and 90%**.

VBR 12 PR



MOD.



Costados  
Sides  
(mm)



Potencia  
Power  
(W)



Capacidad  
Capacity  
(L)



Nº puertas  
Doors



Superficie  
Exposición  
(m<sup>2</sup>)



Estantes  
Shelving



Compresor  
Compressor  
(HP)



Consumo  
Consumption  
(kWh/24h)



Potencia  
frigorífica  
Cooling capacity  
(W a -10°C)



Control



Refrigerante  
Coolant

MOD.	Costados Sides (mm)	Potencia Power (W)	Capacidad Capacity (L)	Nº puertas Doors	Superficie Exposición (m <sup>2</sup> )	Estantes Shelving	Compresor Compressor (HP)	Consumo Consumption (kWh/24h)	Potencia frigorífica Cooling capacity (W a -10°C)	Control	Refrigerante Coolant
VBR 9 PR	20+20	1000	274	2	1,4	3	1/2	16,0	1096	Digital	R-452
VBR 12 PR	20+20	1060	365	2	1,9	3	3/4	17,0	1315	Digital	R-452
VBR 18 PR	20+20	1340	548	3	2,8	3	1	21,4	1840	Digital	R-452



# Pastry display case

Serie  
**AMBAR RECTA**  
Series

## REFRIGERACIÓN



### Refrigeración

Sistema de **Condensación Ventilada**.  
Bandeja **evaporativa** doble.

## REFRIGERATION

### Refrigeration system

System of **Ventilated Condensation**.  
Double **evaporative** tray.

**Posibilidad de intercalar módulo**  
Self service [consultar]

**VBR 12 PR**



**VBR 9 PR**  
**3.729 €**

938 x 810 x 1300 mm.  
Temp. +4°C / +8°C  
C. Clima. 4 / 38°C  
230v/1ph/50 Hz



**VBR 12 PR**  
**4.131 €**

1250 x 810 x 1300 mm.  
Temp. +4°C / +8°C  
C. Clima. 4 / 38°C  
230v/1ph/50 Hz



**VBR 18 PR**  
**5.205 €**

1875 x 810 x 1300 mm.  
Temp. +4°C / +8°C  
C. Clima. 4 / 38°C  
230v/1ph/50 Hz

**VBR PR**

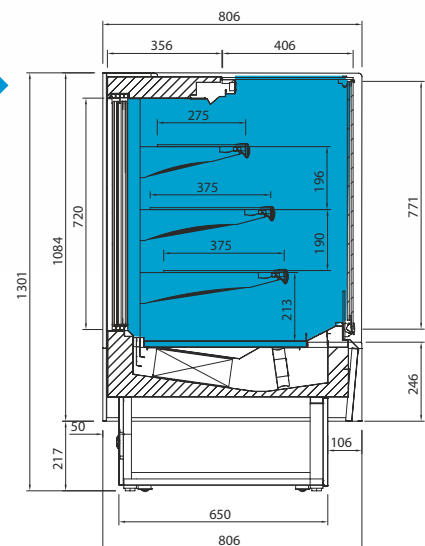

Medidas sin costados  
Measures without sides

Fotografías no contractuales / Non contractual pictures.

Características técnicas y constructivas sujetas a variación sin previo aviso / We reserve the right to change specifications without prior notice.

Los datos técnicos están sujetos a posibles variaciones que serán actualizadas periódicamente en las fichas técnicas del producto, disponibles en la web.

The technical data are subject to possible variations that will be updated periodically in the technical data sheets of the product, which are available on the website.

www.infrico.com



519



# Vitrina caliente expositora para pastelería

Serie  
**AMBAR RECTA**  
Series

## CARACTERÍSTICAS TÉCNICAS

### Control



Mayor precisión en el sistema de control de la temperatura y humedad. Mayor facilidad para el ajuste del intervalo de temperaturas que deseamos conseguir.

### Iluminación



Incorporación de **iluminación LED**, llegando a **reducir** el consumo energético **entre un 80% y 90%**.

## TECHNICAL CHARACTERISTICS

### Control

Higher precision in managing temperature settings. Greater ability to adjust of temperature ranges as per the end user's requirement.

### Lighting

**LED lighting** incorporated, **reducing** energetic consumption **between 80% and 90%**.

VBR 12 PHT



MOD.



Costados  
Sides  
(mm)



Potencia  
Power  
(W)



Capacidad  
Capacity  
(L)



Nº puertas  
Doors



Superficie  
Exposición  
(m<sup>2</sup>)



Estantes  
Shelving



Consumo  
Consumption  
(kWh/24h)



Control

MOD.	Costados Sides (mm)	Potencia Power (W)	Capacidad Capacity (L)	Nº puertas Doors	Superficie Exposición (m <sup>2</sup> )	Estantes Shelving	Consumo Consumption (kWh/24h)	Control
VBR 9 PHT	20+20	570	274	2	1	2	6,8	Digital
VBR 12 PHT	20+20	830	365	2	1,4	2	10,0	Digital
VBR 18 PHT	20+20	1.100	548	3	2,1	2	13,2	Digital



# Pastry display case

Serie  
**AMBAR RECTA**  
Series

## REFRIGERACIÓN



### Sistema calefactor

Resistencia **blindada y aleteada**.  
Bandeja en el interior para **aportar humedad**.  
**Termostato electrónico** trasero.  
**Display temperatura** interno.

## REFRIGERATION

### Heating system

**Reinforced** resistance and **finned**.  
Internal tray to **supply humidity**.  
**Electronic** thermostat.  
Internal **temperatura display**.

VBR 12 PHT



VBR 9 PHT

**3.216 €**

938 x 810 x 1300 mm.  
Temp. +55°C / +60°C



VBR 12 PHT

**3.552 €**

1250 x 810 x 1300 mm.  
Temp. +55°C / +60°C



VBR 18 PHT

**4.508 €**

1875 x 810 x 1300 mm.  
Temp. +55°C / +60°C

Medidas sin costados  
Measures without sides

VBR PHT

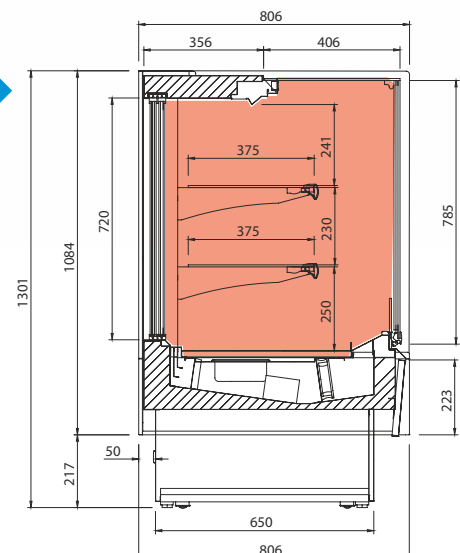



# Vitrina expositora para pastelería

## Pastry display case









# Vitrina expositora para pastelería

Serie  
**ONIX**  
Series

## CARACTERÍSTICAS TÉCNICAS



### Estructura

Acero Inoxidable AISI 304



### Control

Mayor precisión en el sistema de control de la temperatura y humedad. Mayor facilidad para el ajuste del intervalo de temperaturas que deseamos conseguir.



### Iluminación

Incorporación de **iluminación LED**, llegando a **reducir** el consumo energético **entre un 80% y 90%**.

## TECHNICAL CHARACTERISTICS

### Estructure

AISI 304 Stainless Steel

### Control

Higher precision in managing temperature settings. Greater ability to adjust of temperature ranges as per the end user's requirement.

### Lighting

**LED lighting** incorporated, **reducing** energetic consumption **between 80% and 90%**.

VON 12 PR



MOD.



Costados  
Sides  
(mm)



Potencia  
Power  
(W)



Capacidad  
Capacity  
(L)



Nº puertas  
Doors



Superficie  
Exposición  
(m<sup>2</sup>)



Estantes  
Shelving



Compresor  
Compressor  
(HP)



LED



Consumo  
Consumption  
(kWh/24h)



Evaporación  
Evaporation



Potencia  
frigorífica  
Cooling capacity  
(W a -10°C)



Desescarche  
Defrost



Control



Refrigerante  
Coolant

MOD.	Costados Sides (mm)	Potencia Power (W)	Capacidad Capacity (L)	Nº puertas Doors	Superficie Exposición (m <sup>2</sup> )	Estantes Shelving	Compresor Compressor (HP)	LED	Consumo Consumption (kWh/24h)	Evaporación Evaporation	Potencia frigorífica Cooling capacity (W a -10°C)	Desescarche Defrost	Control	Refrigerante Coolant
VON9PR	20+20	1000	274	2	1,4	3	1/2	✓	16,0	Forzada Forced	1096	Automático Automatic	Digital	R-452
VON12PR	20+20	1060	365	2	1,9	3	3/4	✓	17,0	Forzada Forced	1315	Automático Automatic	Digital	R-452
VON18PR	20+20	1340	548	3	2,8	3	1	✓	21,4	Forzada Forced	2192	Automático Automatic	Digital	R-452

Fotografías no contractuales / Non contractual pictures.

Características técnicas y constructivas sujetas a variación sin previo aviso / We reserve the right to change specifications without prior notice.

Los datos técnicos están sujetos a posibles variaciones que serán actualizadas periódicamente en las fichas técnicas del producto, disponibles en la web. The technical data are subject to possible variations that will be updated periodically in the technical data sheets of the product, which are available on the website.



# Pastry display case

Serie  
**ONIX**  
Series

## REFRIGERACIÓN



### Refrigeración

Sistema de **Condensación Ventilada**.

Sistema de **Evaporación Forzada**

Temperatura y desescarche regulada por un **controlador digital**.

## REFRIGERATION

### Refrigeration system

System of **Ventilated Condensation**.

System of **Forced Evaporation**.

Temperature and defrost regulated by a **digital controller**.

VON 12 PR



**VON 9 PR**  
**3.967 €**

938 x 810 x 1300 mm.  
Temp. +4°C / +8°C  
C. Clima. 4 / 38°C  
230v/1ph/50 Hz



**VON 12 PR**  
**4.393 €**

1250 x 810 x 1300 mm.  
Temp. +4°C / +8°C  
C. Clima. 4 / 38°C  
230v/1ph/50 Hz



**VON 18 PR**  
**5.512 €**

1875 x 810 x 1300 mm.  
Temp. +4°C / +8°C  
C. Clima. 4 / 38°C  
230v/1ph/50 Hz

Medidas sin costados  
Measures without sides

VON PR

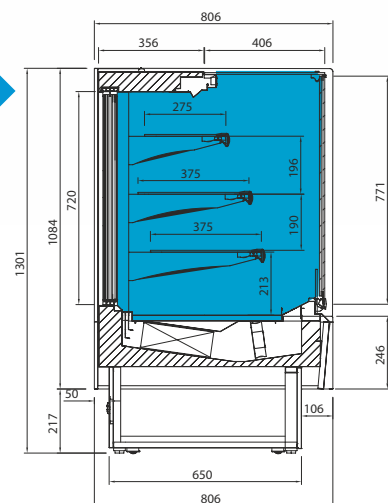

Fotografías no contractuales / Non contractual pictures.

Características técnicas y constructivas sujetas a variación sin previo aviso / We reserve the right to change specifications without prior notice.

Los datos técnicos están sujetos a posibles variaciones que serán actualizadas periódicamente en las fichas técnicas del producto, disponibles en la web.

The technical data are subject to possible variations that will be updated periodically in the technical data sheets of the product, which are available on the website.

www.infrico.com



525



# Vitrina caliente expositora para pastelería

Serie  
**ONIX**  
Series

## CARACTERÍSTICAS TÉCNICAS



### Estructura

Acero Inoxidable AISI 304



### Control

Mayor precisión en el sistema de control de la temperatura y humedad. Mayor facilidad para el ajuste del intervalo de temperaturas que deseamos conseguir.



### Iluminación

Incorporación de **iluminación LED**, llegando a **reducir** el consumo energético **entre un 80% y 90%**.

## TECHNICAL CHARACTERISTICS

### Estructure

AISI 304 Stainless Steel

### Control

Higher precision in managing temperature settings. Greater ability to adjust of temperature ranges as per the end user's requirement.

### Lighting

**LED lighting** incorporated, **reducing** energetic consumption **between 80% and 90%**.

VON 12 PHT



MOD.



Costados  
Sides  
(mm)



Potencia  
Power  
(W)



Capacidad  
Capacity  
(L)



Nº puertas  
Doors



Superficie  
Exposición  
(m<sup>2</sup>)



Estantes  
Shelving



LED



Consumo  
Consumption  
(kWh/24h)



Control

VON9PHT

20+20

570

274

2

1,0

2

✓

6,8

Digital

VON12PHT

20+20

830

365

2

1,4

2

✓

10,0

Digital

VON18PHT

20+20

1100

548

3

2,1

2

✓

13,2

Digital

11

Fotografías no contractuales / Non contractual pictures.

Características técnicas y constructivas sujetas a variación sin previo aviso / We reserve the right to change specifications without prior notice.

Los datos técnicos están sujetos a posibles variaciones que serán actualizadas periódicamente en las fichas técnicas del producto, disponibles en la web. The technical data are subject to possible variations that will be updated periodically in the technical data sheets of the product, which are available on the website.



# Pastry hot display case

Serie  
**ONIX**  
Series

## REFRIGERACIÓN



### Sistema calefactor

Resistencia **blindada y aleteada**.  
Bandeja en el interior para **aportar humedad**.

**Termostato electrónico** trasero.

**Display temperatura** interno.

## REFRIGERATION

### Refrigeration system

**Reinforced** resistance and **finned**.

Internal tray to **supply humidity**.

**Electronic** thermostat.

Internal **temperatura display**.

VON 12 PHT



VON 9 PHT  
**3.412 €**

938 x 810 x 1300 mm.  
Temp. +55°C / +65°C  
C. Clima. 3 / 25°C



VON 12 PHT  
**3.743 €**

1250 x 810 x 1300 mm.  
Temp. +55°C / +65°C  
C. Clima. 3 / 25°C



VON 18 PHT  
**4.913 €**

1875 x 810 x 1300 mm.  
Temp. +55°C / +65°C  
C. Clima. 3 / 25°C

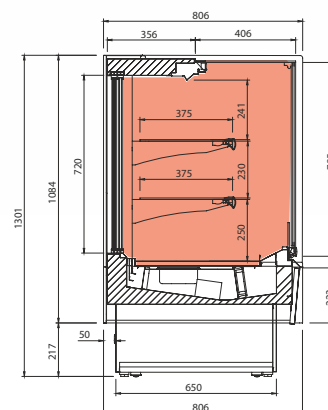

VON PR

V. PASTELERIA  
PASTRY DISPLAY CASES

Medidas sin costados  
Measures without sides

Fotografías no contractuales / Non contractual pictures.

Características técnicas y constructivas sujetas a variación sin previo aviso / We reserve the right to change specifications without prior notice.

Los datos técnicos están sujetos a posibles variaciones que serán actualizadas periódicamente en las fichas técnicas del producto, disponibles en la web.

The technical data are subject to possible variations that will be updated periodically in the technical data sheets of the product, which are available on the website.

www.infrico.com



527



# Vitrina expositora para pastelería

Serie  
**ONIX**  
Series

## CARACTERÍSTICAS TÉCNICAS



### Estructura

Acero Inoxidable AISI 304



### Control

Mayor precisión en el sistema de control de la temperatura y humedad. Mayor facilidad para el ajuste del intervalo de temperaturas que deseamos conseguir.



### Iluminación

Incorporación de **iluminación LED**, llegando a **reducir** el consumo energético **entre un 80% y 90%**.

## TECHNICAL CHARACTERISTICS

### Estructure

AISI 304 Stainless Steel

### Control

Higher precision in managing temperature settings. Greater ability to adjust of temperature ranges as per the end user's requirement.

### Lighting

**LED lighting** incorporated, **reducing** energetic consumption **between 80% and 90%**.

VON 9 R



MOD.



Costados  
Sides  
(mm)



Potencia  
Power  
(W)



Capacidad  
Capacity  
(L)



Nº puertas  
Doors



Superficie  
Exposición  
(m<sup>2</sup>)



Estantes  
Shelving



Compresor  
Compressor  
(HP)



LED



Consumo  
Consumption  
(kWh/24h)



Evaporación  
Evaporation



Potencia  
frigorífica  
Cooling capacity  
(W a -10°C)



Desescarche  
Defrost



Control



Refrigerante  
Coolant

MOD.	Costados Sides (mm)	Potencia Power (W)	Capacidad Capacity (L)	Nº puertas Doors	Superficie Exposición (m <sup>2</sup> )	Estantes Shelving	Compresor Compressor (HP)	LED	Consumo Consumption (kWh/24h)	Evaporación Evaporation	Potencia frigorífica Cooling capacity (W a -10°C)	Desescarche Defrost	Control	Refrigerante Coolant
VON 9R	20+20	1000	274	2	1,4	3	1/2	✓	16,0	Forzada Forced	1096	Automático Automatic	Digital	R-452
VON 12R	20+20	1060	365	2	1,9	3	3/4	✓	17,0	Forzada Forced	1315	Automático Automatic	Digital	R-452
VON 18R	20+20	1340	548	3	2,8	3	1	✓	21,4	Forzada Forced	1840	Automático Automatic	Digital	R-452
VON 9HT	20+20	570	274	2	1,0	2	-	✓	20,0	-	-	-	Digital	-
VON 12HT	20+20	830	365	2	1,4	2	-	✓	21,2	-	-	-	Digital	-
VON 18HT	20+20	1100	548	3	2,1	2	-	✓	36,8	-	-	-	Digital	-

Fotografías no contractuales / Non contractual pictures.

Características técnicas y constructivas sujetas a variación sin previo aviso / We reserve the right to change specifications without prior notice.

Los datos técnicos están sujetos a posibles variaciones que serán actualizadas periódicamente en las fichas técnicas del producto, disponibles en la web.  
The technical data are subject to possible variations that will be updated periodically in the technical data sheets of the product, which are available on the website.



# Pastry display case

Serie  
**ONIX**  
Series

## REFRIGERACIÓN



### Sistema calefactor

Resistencia **blindada y aleteada**.  
Bandeja en el interior para **aportar humedad**.  
**Termostato electrónico** trasero.  
**Display temperatura** interno.

## REFRIGERATION

### Refrigeration system

**Reinforced** resistance and **finned**.  
Internal tray to **supply humidity**.  
**Electronic** thermostat.  
Internal **temperatura display**.

VON 9 R



OPCIONAL Cristal frontal doble  
OPTIONAL Double frontal glass



VON 9 HT  
**3.236 €**

938 x 810 x 1300 mm.  
Temp. +55°C / +65°C  
230v/1ph/50 Hz



VON 12 HT  
**3.535 €**

1250 x 810 x 1300 mm.  
Temp. +55°C / +65°C  
230v/1ph/50 Hz



VON 18 HT  
**4.599 €**

1875 x 810 x 1300 mm.  
Temp. +55°C / +65°C  
230v/1ph/50 Hz

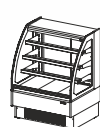

VON 9 R  
**3.687 €**

938 x 810 x 1300 mm.  
Temp. +4°C / +8°C  
230v/1ph/50 Hz

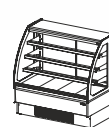

VON 12 R  
**4.074 €**

1250 x 810 x 1300 mm.  
Temp. +4°C / +8°C  
230v/1ph/50 Hz

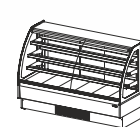

VON 18 R  
**5.043 €**

1875 x 810 x 1300 mm.  
Temp. +4°C / +8°C  
230v/1ph/50 Hz

Medidas sin costados  
Measures without sides

Fotografías no contractuales / Non contractual pictures.

Características técnicas y constructivas sujetas a variación sin previo aviso / We reserve the right to change specifications without prior notice.

Los datos técnicos están sujetos a posibles variaciones que serán actualizadas periódicamente en las fichas técnicas del producto, disponibles en la web.

The technical data are subject to possible variations that will be updated periodically in the technical data sheets of the product, which are available on the website.

www.infrico.com



529



# Vitrina expositora para pastelería autoservicio

Serie  
**ONIX**  
Series

## CARACTERÍSTICAS TÉCNICAS



### Estructura

Acero Inoxidable AISI 304



### Control

Mayor precisión en el sistema de control de la temperatura y humedad. Mayor facilidad para el ajuste del intervalo de temperaturas que deseamos conseguir.



### Iluminación

Incorporación de **iluminación LED**, llegando a **reducir** el consumo energético **entre un 80% y 90%**.

## TECHNICAL CHARACTERISTICS

### Estructure

AISI 304 Stainless Steel

### Control

Higher precision in managing temperature settings. Greater ability to adjust of temperature ranges as per the end user's requirement.

### Lighting

**LED lighting** incorporated, **reducing** energetic consumption **between 80% and 90%**.

VON 6 SS



VON DS

Doble servicio  
Double service



MOD.	Costados Sides (mm)	Potencia Power (W)	Capacidad Capacity (L)	Nº puertas Doors	Superficie Exposición (m <sup>2</sup> )	Estantes Shelving	Compresor Compressor (HP)	LED	Consumo Consumption (kWh/24h)	Evaporación Evaporation	Potencia frigorífica Cooling capacity (W a -10°C)	Desescarche Defrost	Control	Refrigerante Coolant
VON 6SS	20+20	825	180	-	0,9	3	1/3	✓	16,5	Forzada Forced	750	Automático Automatic	Digital	R-452
VON 9SS	20+20	1000	274	-	1,4	3	1/2	✓	18,2	Forzada Forced	196	Automático Automatic	Digital	R-452
VON 12SS	20+20	1060	365	-	1,9	3	3/4	✓	21,2	Forzada Forced	1315	Automático Automatic	Digital	R-452
VON 18SS	20+20	1340	548	-	2,8	3	1	✓	26,8	Forzada Forced	1840	Automático Automatic	Digital	R-452
VON 9DS	20+20	1000	274	2	1,4	3	1/2	✓	20,0	Forzada Forced	1096	Automático Automatic	Digital	R-452
VON 12DS	20+20	1060	365	2	1,9	3	3/4	✓	21,2	Forzada Forced	1315	Automático Automatic	Digital	R-452
VON 18DS	20+20	1340	548	4	2,8	3	1/2+1/2	✓	36,8	Forzada Forced	2192	Automático Automatic	Digital	R-452



# Self service pastry display case

Serie  
**ONIX**  
Series

## REFRIGERACIÓN



### Refrigeración

Sistema de **Condensación Ventilada**.

Sistema de **Evaporación Forzada**

Temperatura y desescarche regulada por un **controlador digital**.

Bandeja evaporativa doble por **gas caliente**.

## REFRIGERATION

### Refrigeration system

System of **Ventilated Condensation**.

System of **Forced Evaporation**.

Temperature and defrost regulated by a **digital controller**.

Double evaporative tray by **gas defrost**.

VON 6 SS



**VON 9 DS**  
**3.733 €**

938 x 810 x 1300 mm.  
Temp. +4°C / +8°C  
230v/1ph/50 Hz



**VON 12 DS**  
**4.163 €**

1250 x 810 x 1300 mm.  
Temp. +4°C / +8°C  
230v/1ph/50 Hz



**VON 18 DS**  
**6.561 €**

1875 x 810 x 1300 mm.  
Temp. +4°C / +8°C  
230v/1ph/50 Hz



**VON 6 SS**  
**3.141 €**

625 x 810 x 1300 mm.  
Temp. +4°C / +8°C  
230v/1ph/50 Hz



**VON 9 SS**  
**3.561 €**

938 x 810 x 1300 mm.  
Temp. +4°C / +8°C  
230v/1ph/50 Hz

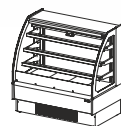

**VON 12 SS**  
**3.959 €**

1250 x 810 x 1300 mm.  
Temp. +4°C / +8°C  
230v/1ph/50 Hz

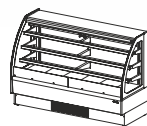

**VON 18 SS**  
**5.041 €**

1875 x 810 x 1300 mm.  
Temp. +4°C / +8°C  
230v/1ph/50 Hz

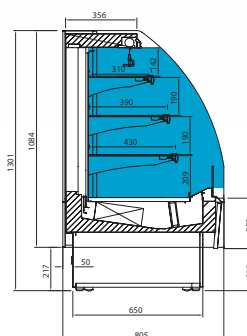

VON SS

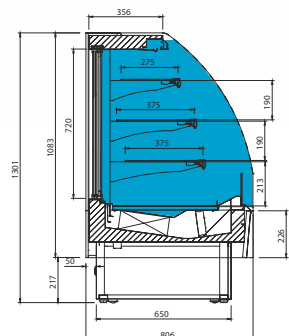

VON DS

Medidas sin costados  
Measures without sides

Fotografías no contractuales / Non contractual pictures.

Características técnicas y constructivas sujetas a variación sin previo aviso / We reserve the right to change specifications without prior notice.

Los datos técnicos están sujetos a posibles variaciones que serán actualizadas periódicamente en las fichas técnicas del producto, disponibles en la web.

The technical data are subject to possible variations that will be updated periodically in the technical data sheets of the product, which are available on the website.

www.infrico.com



531





# Vitrina refrigerada expositora para pastelería y panadería

Serie  
**MARIE**  
Series

## CARACTERÍSTICAS TÉCNICAS

### Control



Mayor precisión en el sistema de control de la temperatura y humedad. Mayor facilidad para el ajuste del intervalo de temperaturas que deseamos conseguir.



### Comprobación de fuga de gas

Todos los circuitos frigoríficos son **comprobados al 100%, en cámara de Helio** para la detección de la fuga de gas.

## TECHNICAL CHARACTERISTICS

### Control

Higher precision in managing temperature settings. Greater ability to adjust of temperature ranges as per the end user's requirement.

### Leak detection system

All the condensing units are **100% tested, in a Helium chamber** for the detection of gas leakage.

VMR 2000



MOD.	Potencia Power (W)	Capacidad Capacity (L)	Nº puertas Doors	Superficie Exposición (m <sup>2</sup> )	Estantes Shelving	Compresor Compressor (HP)	Consumo Consumption (kWh/24h)	Evaporación Evaporation	Potencia frigorífica Cooling capacity (W a -10°C)	Desescarche Defrost	Control	Refrigerante Coolant
VMR1500	1060	180	2	0,93	2	1/2	17,00	Forzada Forced	1315	Automático Automatic	Digital	R-452
VMR2000	1060	235	2	1,25	3	3/4	18,00	Forzada Forced	1315	Automático Automatic	Digital	R-452



# Pastry display case

Serie  
**MARIE**  
Series

## REFRIGERACIÓN



### Refrigeración

**Termostato electrónico** trasero.

Sistema de **Condensación Ventilada**.

Sistema de **Evaporación Forzada**.

Bandeja evaporativa en acero inoxidable con doble cuba, una a **gas caliente** y otra con Resistencia eléctrica.

## REFRIGERATION

### Refrigeration system

Electronic thermostat

System of **Ventilated Condensation**.

System of **Forced Evaporation**.

Stainless steel double evaporative tray **by hot gas defrost**.

VMR 1500

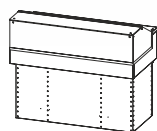

VMR 1500

**3.186 €**

1155 x 830 x 1290 mm.  
Temp. +2°C / +5°C  
C. Clima. 4 / 38°C  
230v/1 ph/50 Hz

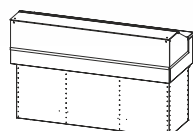

VMR 2000

**3.613 €**

2005 x 830 x 1290 mm.  
Temp. +2°C / +5°C  
C. Clima. 4 / 38°C  
230v/1 ph/50 Hz

VMR

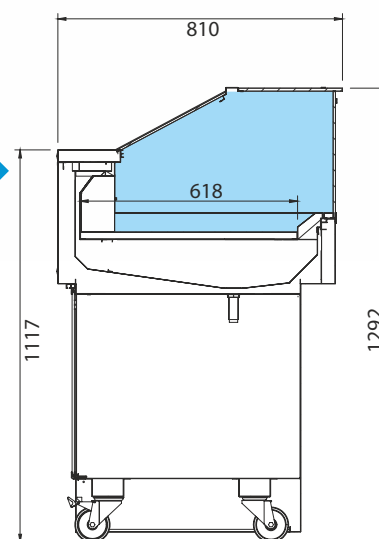



# Vitrina expositora para cafetería y pastelería

## Pastry display case



Serie  
**COMBO**  
Series



V. PASTERIA  
PASTRY DISPLAY CASES



# Vitrina expositora para cafetería y pastelería

Serie  
**COMBO**  
Series

## CARACTERÍSTICAS TÉCNICAS

### Control



Mayor precisión en el sistema de control de la temperatura y humedad. Mayor facilidad para el ajuste del intervalo de temperaturas que deseamos conseguir.



### Comprobación de fuga de gas

Todos los circuitos frigoríficos son **comprobados al 100%, en cámara de Helio** para la detección de la fuga de gas.



### Iluminación

Incorporación de **iluminación LED**, llegando a **reducir** el consumo energético **entre un 80% y 90%**.

## TECHNICAL CHARACTERISTICS

### Control

Higher precision in managing temperature settings. Greater ability to adjust of temperature ranges as per the end user's requirement.







### Leak detection system

All the condensing units are **100% tested, in a Helium chamber** for the detection of gas leakage.

### Lighting

**LED lighting** incorporated, **reducing** energetic consumption **between 80% and 90%**.



MOD.	 Potencia Power (W)	 Capacidad Capacity (L)	 Estantes Shelving	 Compresor Compressor (HP)	 Control	 Refrigerante Coolant	 De serie Standard
VC09	1015	214	1	5/8	Digital	R-452	Cortina nocturna Night curtain
VC012	1070	280	1	3/4	Digital	R-452	Cortina nocturna Night curtain
VC015	1310	347	1	7/8	Digital	R-452	Cortina nocturna Night curtain
VC018	1405	414	1	1	Digital	R-452	Cortina nocturna Night curtain



# Pastry display case

Serie  
**COMBO**  
Series

## REFRIGERACIÓN



### Refrigeración

**Termostato electrónico** trasero.  
Sistema de **Condensación Ventilada**.  
Sistema de **Evaporación Forzada**.  
Bandeja evaporativa en acero inoxidable con **doble cuba**.

## REFRIGERATION

### Refrigeration system

Rear **electronic thermostat**.  
System of **Ventilated Condensation**.  
**Forced air refrigeration** system.  
Stainless Steel Evaporative **double trays**.

VCO 15



**VCO 9**  
**4.168 €**

998 x 890 x 1455 mm.  
Temp. +2°C / +5°C  
C. Clima. 3 / 25°C  
230v/1ph/50 Hz



**VCO 12**  
**4.536 €**

1310 x 890 x 1455 mm.  
Temp. +2°C / +5°C  
C. Clima. 3 / 25°C  
230v/1ph/50 Hz



**VCO 15**  
**5.090 €**

1622 x 890 x 1455 mm.  
Temp. +2°C / +5°C  
C. Clima. 3 / 25°C  
230v/1ph/50 Hz

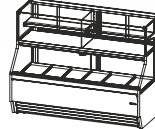

**VCO 18**  
**5.354 €**

1935 x 890 x 1455 mm.  
Temp. +2°C / +5°C  
C. Clima. 3 / 25°C  
230v/1ph/50 Hz

VCO

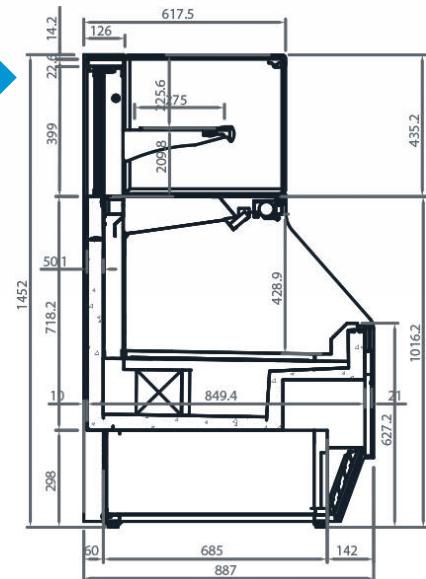

Fotografías no contractuales / Non contractual pictures.

Características técnicas y constructivas sujetas a variación sin previo aviso / We reserve the right to change specifications without prior notice.

Los datos técnicos están sujetos a posibles variaciones que serán actualizadas periódicamente en las fichas técnicas del producto, disponibles en la web.

The technical data are subject to possible variations that will be updated periodically in the technical data sheets of the product, which are available on the website.

www.infrico.com



537



# Vitrina expositora para panadería y pastelería

## Pastry display case



Serie  
**MAGNUS**  
Series



V. PASTELERIA  
PASTRY DISPLAY CASES





# Vitrina expositora frío ventilado modular para panadería y pastelería con reserva

Serie  
**MAGNUS**  
Series

## CARACTERÍSTICAS TÉCNICAS

### Control



Mayor precisión en el sistema de control de la temperatura y humedad. Mayor facilidad para el ajuste del intervalo de temperaturas que deseamos conseguir.



### Comprobación de fuga de gas

Todos los circuitos frigoríficos son **comprobados al 100%, en cámara de Helio** para la detección de la fuga de gas.



### Iluminación

Incorporación de **iluminación LED**, llegando a **reducir** el consumo energético **entre un 80% y 90%**.

## TECHNICAL CHARACTERISTICS

### Control

Higher precision in managing temperature settings. Greater ability to adjust of temperature ranges as per the end user's requirement.

### Leak detection system

All the condensing units are **100% tested, in a Helium chamber** for the detection of gas leakage.

### Lighting

**LED lighting** incorporated, **reducing** energetic consumption **between 80% and 90%**.



### MOD.

**Puertas correderas traseras**  
Night sliding doors

**Precio**  
Price (€)

Model	Option	Price (€)
VMG 9 R	PUEVMG9CT	120 €
VMG 12 R	PUEVMG12CT	175 €
VMG 15 R	PUEVMG15CT	232 €
VMG 18 R	PUEVMG18CT	287 €
VMG 25 R	PUEVMG25CT	355 €

**Opción Puertas correderas traseras**  
Option Rear sliding doors

### MOD.



**Costados**  
Sides (mm)



**Potencia**  
Power (W)



**Capacidad**  
Capacity (L)



**Nº puertas**  
Doors



**Superficie**  
Exposición (m<sup>2</sup>)



**Estantes**  
Shelving



**Compresor**  
Compressor (HP)



**Consumo**  
Consumption (kWh/24h)



**Potencia frigorífica**  
Cooling capacity (W a -10°C)



**Desescarche**  
Defrost



**Control**



**Refrigerante**  
Coolant

Model	Costados (mm)	Potencia (W)	Capacidad (L)	Nº puertas	Superficie (m <sup>2</sup> )	Estantes	Compresor (HP)	Consumo (kWh/24h)	Potencia frigorífica (W a -10°C)	Desescarche	Control	Refrigerante
VMG 9 R	60+60	738	103	1	0,6	2	3/8	11,8	676	Automático	Digital	R-452
VMG 12 R	60+60	988	138	2	0,8	2	5/8	15,8	1096	Automático	Digital	R-452
VMG 12 B	60+60	738	138	-	0,8	2	3/8	11,8	676	Automático	Digital	R-452
VMG 15 R	60+60	1070	172	2	0,9	2	3/4	17,1	1315	Automático	Digital	R-452
VMG 18 R	60+60	1263	206	3	1,1	2	1	20,2	1506	Automático	Digital	R-452
VMG 25 R	60+60	1495	275	4	1,5	2	1 1/6	23,9	2009	Automático	Digital	R-452

Fotografías no contractuales / Non contractual pictures.

Características técnicas y constructivas sujetas a variación sin previo aviso / We reserve the right to change specifications without prior notice.

Los datos técnicos están sujetos a posibles variaciones que serán actualizadas periódicamente en las fichas técnicas del producto, disponibles en la web. The technical data are subject to possible variations that will be updated periodically in the technical data sheets of the product, which are available on the website.



# Refrigerated modular pastry display case with storage

Serie  
**MAGNUS**  
Series

## REFRIGERACIÓN



**Desescarche** automático.  
Sistema de **Condensación Ventilada**.  
Sistema de **Evaporación Forzada**.  
Bandeja evaporativa doble por **gas caliente**.

## REFRIGERATION

Automatic **defrost**.  
System of **Ventilated Condensation**.  
System of **Forced Evaporation**.  
**Double evaporative trays by hot gas defrost**.

VMG12R



**VMG 9 R**  
**3.938 €**

938 x 990 x 1345 mm.  
Temp. +4°C / +8°C  
C. Clima. 3 / 25°C  
230v/1ph/50 Hz



**VMG 12 R**  
**4.429 €**

1250 x 990 x 1345 mm.  
Temp. +4°C / +8°C  
C. Clima. 3 / 25°C  
230v/1ph/50 Hz



**VMG 12 B**  
**4.754 €**

1250 x 990 x 1300 mm.  
Temp. +7°C / +12°C  
C. Clima. 3 / 25°C  
230v/1ph/50 Hz

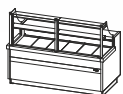

**VMG 15 R**  
**5.234 €**

1562 x 990 x 1345 mm.  
Temp. +4°C / +8°C  
C. Clima. 3 / 25°C  
230v/1ph/50 Hz

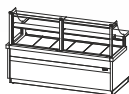

**VMG 18 R**  
**5.717 €**

1875 x 990 x 1345 mm.  
Temp. +4°C / +8°C  
C. Clima. 3 / 25°C  
230v/1ph/50 Hz

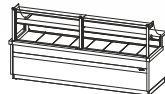

**VMG 25 R**  
**6.443 €**

2500 x 990 x 1345 mm.  
Temp. +4°C / +8°C  
C. Clima. 3 / 25°C  
230v/1ph/50 Hz

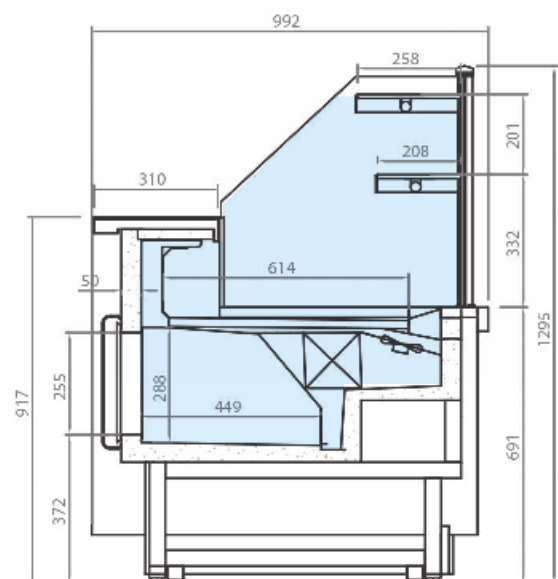

VMG12R

Fotografías no contractuales / Non contractual pictures.

Características técnicas y constructivas sujetas a variación sin previo aviso / We reserve the right to change specifications without prior notice.

Los datos técnicos están sujetos a posibles variaciones que serán actualizadas periódicamente en las fichas técnicas del producto, disponibles en la web.

The technical data are subject to possible variations that will be updated periodically in the technical data sheets of the product, which are available on the website.

www.infrico.com



541



# Vitrina expositora frío ventilado modular para panadería y pastelería con reserva

Serie  
**MAGNUS**  
Series

MOD.	Puertas correderas traseras Night sliding doors	Precio Price [€]
VMG45AAR	PUEVMG45AACT	100 €
VMG45ACR	PUEVMG45ACCT	158 €
VMG90AAR	PUEVMG90AACT	200 €
VMG90ACR	PUEVMG90ACCT	316 €
VMG90ARR	PUEVMG90ARCT	285 €

**Opción Puertas correderas traseras ángulos**  
Option Rear sliding doors angles

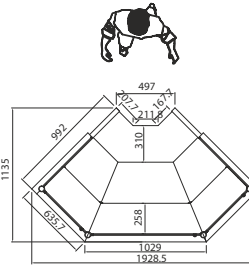

VMG 90 AA R

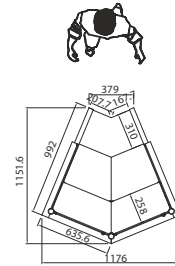

VMG 45 AA R



MOD.	Costados Sides (mm)	Potencia Power (W)	Capacidad Capacity (L)	Nº puertas Doors	Superficie Exposición (m <sup>2</sup> )	Estantes Shelving	Compresor Compressor (HP)	LED	Consumo Consumption (kWh/24h)	Potencia frigorífica Cooling capacity (W a -10°C)	Control	Refrigerante Coolant
VMG 90 AA R	60+60	988	-	-	0,9	2	5/8	✓	15,8	1096	Digital	R-452
VMG 90 AC R	60+60	1060	-	-	1,2	2	3/4	✓	17,0	1315	Digital	R-452
VMG 90 A R	60+60	1060	-	-	1,1	2	3/4	✓	17,0	1315	Digital	R-452
VMG 45 AA R	60+60	662	-	-	0,8	2	3/8	✓	10,6	676	Digital	R-452
VMG 45 AC R	60+60	738	-	-	0,9	2	1/2	✓	11,8	817	Digital	R-452



# Refrigerated modular pastry display case with storage

Serie  
**MAGNUS**  
Series

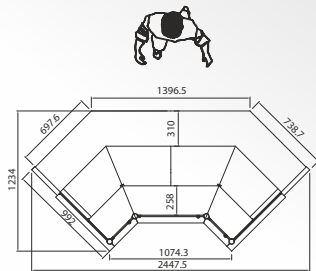

VMG 90 AC R

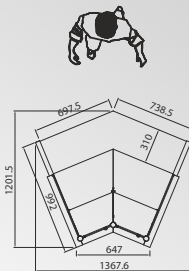

VMG 45 AC R

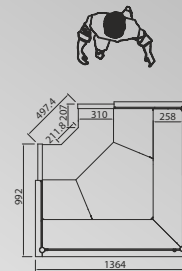

VMG 90 A RR

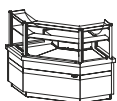

**VMG 90 AA R**  
**6.425 €**

1365 x 990 x 1345 mm.  
Temp. +4°C / +8°C  
C. Clima. 3 / 25°C  
230v/1ph/50 Hz



**VMG 90 AC R**  
**6.943 €**

1750 x 990 x 1345 mm.  
Temp. +4°C / +8°C  
C. Clima. 3 / 25°C  
230v/1ph/50 Hz



**VMG 90 A RR**  
**5.932 €**

1365 x 990 x 1345 mm.  
Temp. +7°C / +12°C  
C. Clima. 3 / 25°C  
230v/1ph/50 Hz



**VMG 45 AA R**  
**4.932 €**

1180 x 990 x 1345 mm.  
Temp. +4°C / +8°C  
C. Clima. 3 / 25°C  
230v/1ph/50 Hz



**VMG 45 AC R**  
**4.979 €**

1365 x 990 x 1345 mm.  
Temp. +4°C / +8°C  
C. Clima. 3 / 25°C  
230v/1ph/50 Hz

Medidas sin costados  
Measures without sides

Fotografías no contractuales / Non contractual pictures.

Características técnicas y constructivas sujetas a variación sin previo aviso / We reserve the right to change specifications without prior notice.

Los datos técnicos están sujetos a posibles variaciones que serán actualizadas periódicamente en las fichas técnicas del producto, disponibles en la web.

The technical data are subject to possible variations that will be updated periodically in the technical data sheets of the product, which are available on the website.

www.infrico.com



543



# Vitrina expositora modular neutra (panera)

## Neutral modular display case

Serie  
**MAGNUS**  
Series

### CARACTERÍSTICAS TÉCNICAS



#### Estructura

Encimera de trabajo en **compac quartz blanco**.  
Plano de exposición en **madera**.  
Decoración en **DM hidrófugo**.  
**Vidrios frontales** batientes para una cómoda limpieza.  
Plano de exposición y estantes iluminados mediante **LED**.  
Cajón **recoge migas**.

### TECHNICAL CHARACTERISTICS

#### Estructure

White **compac quartz** worktop.  
**Wood** exhibition area.  
**DM lacqued** water resistant decortion.  
Front and sides tempered **security glass** system.  
**LED lighting** frontal decoration.  
Drawer **gathers crumbs**.

VMG12P



VMG 9 P  
**3.000 €**

938 x 990 x 1345 mm.

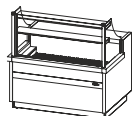

VMG 12 P  
**3.281 €**

1250 x 990 x 1345 mm.

Medidas sin costados  
Measures without sides

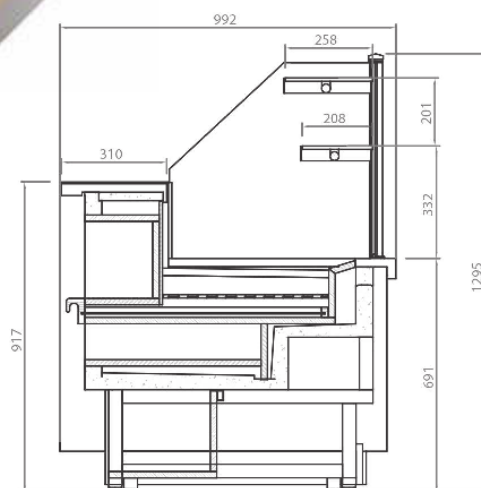

VMG P

MOD.



Costados  
Sides  
(mm)



Potencia  
Power  
(W)



Superficie  
Exposición  
(m<sup>2</sup>)



Estantes  
Shelving



Consumo  
Consumption  
(kWh/24h)

Modelo	Costados Sides (mm)	Potencia Power (W)	Superficie Exposición (m <sup>2</sup> )	Estantes Shelving	Consumo Consumption (kWh/24h)
VMG 9 P	60+60	24	0,6	2	0,4
VMG 12 P	60+60	30	0,8	2	0,5



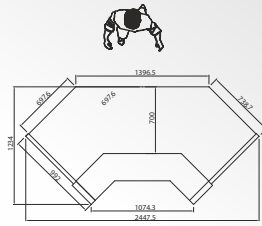

VMG 90 ACM

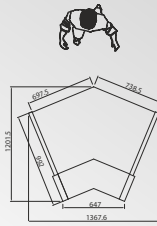

VMG 45 ACM

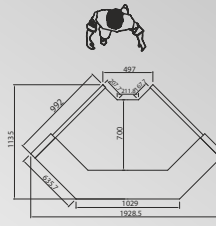

VMG 90 AAM

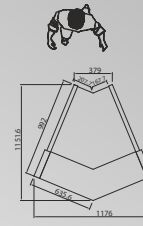

VMG 45 AAM

VMG90AAM

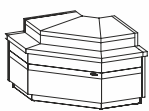

VMG 90 AA M

**3.054 €**

1365 x 990 x 1345 mm.

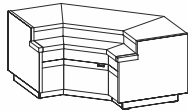

VMG 90 AC M

**3.701 €**

1750 x 990 x 1345 mm.



VMG 45 AA M

**2.403 €**

1180 x 990 x 920 mm.

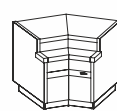

VMG 45 AC M

**3.221 €**

1365 x 990 x 920 mm.

Medidas sin costados  
Measures without sides

MOD.



Costados  
Sides  
[mm]



Potencia  
Power  
[W]



Tensión/  
Frecuencia  
Electrical  
[V/Hz]



LED



Consumo  
Consumption  
[kWh/24h]

	Costados Sides [mm]	Potencia Power [W]	Tensión/ Frecuencia Electrical [V/Hz]	LED	Consumo Consumption [kWh/24h]
VMG 90 AA M	60+60	7	230/50	✓	0,1
VMG 90 AC M	60+60	10	230/50	✓	0,2
VMG 45 AA M	60+60	5	230/50	✓	0,1
VMG 45 AC M	60+60	7	230/50	✓	





## CARACTERÍSTICAS TÉCNICAS



### Estructura

Encimera de trabajo y apoyo bolsos en **Compac Quartz Blanco**.

Decoración en **DM lacado**.

Franja iluminada con **LED** en la decoración frontal.

Estantes traseros en **madera estratificada** blanca.

## TECHNICAL CHARACTERISTICS

### Estructure

Worktop and supports handbags in **compac quartz**.

**DM lacqued** water resistant decortion.

**LED lighting** frontal decoration.

Structure and rear shelves in white **laminated wood**.

**VMG12M**

Nogal/Walnut



**VMG 9 C**

**1.716 €**

938 x 810 x 1300 mm.

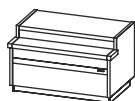

**VMG 12 M**

**2.175 €**

1250 x 810 x 1300 mm.



**VMG 18 M**

**2.927 €**

1250 x 810 x 1300 mm.

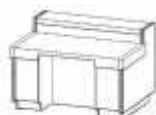

**VMG 12 MHD**

**2.494 €**

1250 x 810 x 1300 mm.

Medidas sin costados  
Measures without sides

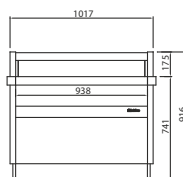

VMG 9 C

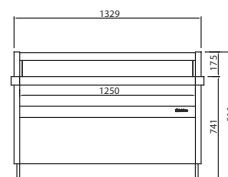

VMG 12 M

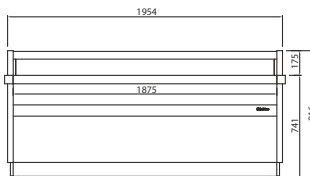

VMG 18 M

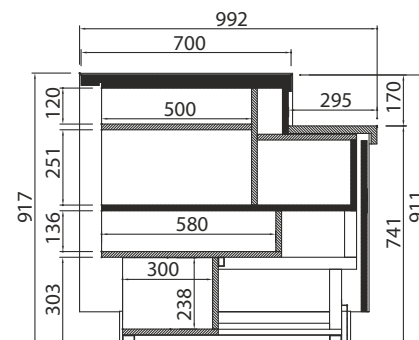

**MOD.**



Costados  
Sides  
(mm)



Potencia  
Power  
(W)



Tensión/  
Frecuencia  
Electrical  
(V/Hz)



Consumo  
Consumption  
(kWh/24h)

MOD.	Costados Sides (mm)	Potencia Power (W)	Tensión/ Frecuencia Electrical (V/Hz)	Consumo Consumption (kWh/24h)
VMG 9 C	60+60	5	230/50	0,1
VMG 12 M	60+60	7	230/50	0,1
VMG 18 M	60+60	10	230/50	0,2
VMG 12MHD	60+60	7	230/50	0,1





**VMG R**  
**RAL 3020**  
 Rojo / Red

**VMG R**  
**RAL 5015**  
 Azul / Blue

**VMG R**  
**RAL DESIGN 1107060**  
 Pistacho / Pistachio

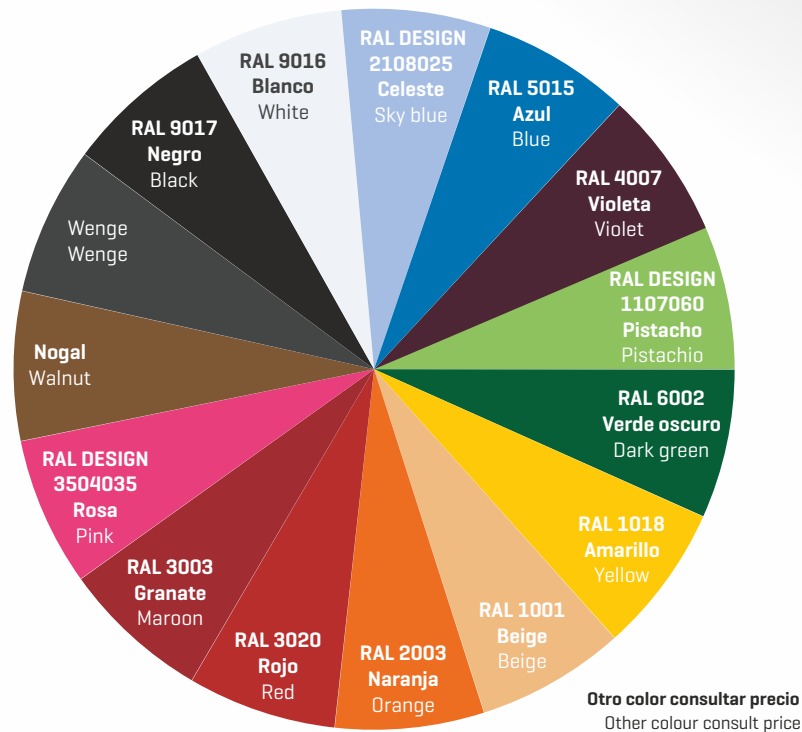
**VMG R**  
**RAL DESIGN 2108025**  
 Celeste / Sky blue

**Decoración Standard / Standar Decorations**

**Colores fuera de carta / Colors outside of letter**

Color	Tipo Type	Incremento plazo de entrega Increase delivery time	Suplemento PVP (x pedido) PVP supplement (x order)
RAL	Epoxi	+10 días laborables/ Work days	675,00 €
	Líquida/Liquid	+10 días laborables/ Work days	420,00 €
NO RAL	Epoxi	Consultar/Consulter	Consultar/Consulter
	Líquida/Liquid	Consultar/Consulter	Consultar/Consulter





# Vitrina expositora para helados

## Gelato display case



Serie  
**CORAL**  
Series



V. PASTERIA  
PASTRY DISPLAY CASES



# Vitrina expositora helados

Serie  
**CORAL**  
Series

## CARACTERÍSTICAS TÉCNICAS

### Control



Mayor precisión en el sistema de control de la temperatura y humedad. Mayor facilidad para el ajuste del intervalo de temperaturas que deseamos conseguir.

### Iluminación



Incorporación de **iluminación LED**, llegando a **reducir** el consumo energético **entre un 80% y 90%**.

## TECHNICAL CHARACTERISTICS

### Control

Higher precision in managing temperature settings. Greater ability to adjust of temperature ranges as per the end user's requirement.

### Lighting

**LED lighting** incorporated, **reducing** energetic consumption **between 80% and 90%**.

VBG 18 H



**RAL 3003**  
**Granate**  
Maroon



**Cristal abatible**  
Tilt forward glass



**Combinación de bandejas**  
Combination of trays

MOD.



Costados  
Sides  
(mm)



Potencia  
Power  
(W)



Superficie  
Exposición  
(m<sup>2</sup>)



Bandejas  
Trays  
(360x165x150)



Bandejas  
Trays  
(360x250x80)



Compresor  
Compressor  
(HP)



Led



Consumo  
Consumption  
(kWh/24h)



Evaporación  
Evaporation



Control



Refrigerante  
Coolant

MOD.	Costados Sides (mm)	Potencia Power (W)	Superficie Exposición (m <sup>2</sup> )	Bandejas Trays (360x165x150)	Bandejas Trays (360x250x80)	Compresor Compressor (HP)	Led	Consumo Consumption (kWh/24h)	Evaporación Evaporation	Control	Refrigerante Coolant
VCB12H	30+30	1250	1,01	14	8	1 1/4	✓	17,5	Forzada Forced	Digital	R-452
VCB15H	30+30	1570	1,32	16	10	1+1/2	✓	24,5	Forzada Forced	Digital	R-452
VCB18H	30+30	1925	1,49	20	14	1 1/4 + 3/4	✓	30,8	Forzada Forced	Digital	R-452

Fotografías no contractuales / Non contractual pictures.

Características técnicas y constructivas sujetas a variación sin previo aviso / We reserve the right to change specifications without prior notice.

Los datos técnicos están sujetos a posibles variaciones que serán actualizadas periódicamente en las fichas técnicas del producto, disponibles en la web. The technical data are subject to possible variations that will be updated periodically in the technical data sheets of the product, which are available on the website.



# Gelato display case

Serie  
**CORAL**  
Series

## REFRIGERACIÓN



### Refrigeración

Sistema de **condensación ventilada**.  
**Control temperatura** final del desescarche.  
Desescarche por **gas caliente**.

## REFRIGERATION

### Refrigeration

**Forced air refrigeration** system.  
**Control** of the final defrost **temperature**.  
**Hot gas** defrost.



**RAL DESIGN 1107060**  
**Pistachio**  
Pistachio



**Cortina nocturna**  
Night curtain



**Bandeja evaporativa extraíble**  
Removable evaporation tray



**VCB12H**  
**7.250 €**

1250 x 1115 x 1320 mm.  
Temp. -15°C / -18°C  
C. Clima. 7  
230v/1ph/50 Hz



**VCB15H**  
**8.229 €**

1562 x 1115 x 1320 mm.  
Temp. -15°C / -18°C  
C. Clima. 7  
230v/1ph/50 Hz

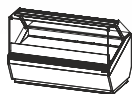

**VCB18H**  
**9.177 €**

1875 x 1115 x 1320 mm.  
Temp. -15°C / -18°C  
C. Clima. 7  
230v/1ph/50 Hz

**Combinación de bandejas**  
**[360x165x150]**  
Tray combinations [360x165x150]

[501X32] x 14uds. **567 €**

[501X32] x 16uds. **648 €**

[501X32] x 20uds. **810 €**

**Combinación de bandejas**  
**[360x250x80]**  
Tray combinations [360x250x80]

[501X36] x 8uds. **333 €**

[501X36] x 10uds. **415 €**

[501X36] x 14uds. **581 €**

**230v/1ph/60 Hz +6%**

**Medidas sin costados**  
Measures without sides

Fotografías no contractuales / Non contractual pictures.

Características técnicas y constructivas sujetas a variación sin previo aviso / We reserve the right to change specifications without prior notice.

Los datos técnicos están sujetos a posibles variaciones que serán actualizadas periódicamente en las fichas técnicas del producto, disponibles en la web.

The technical data are subject to possible variations that will be updated periodically in the technical data sheets of the product, which are available on the website.

www.infrico.com



551



# Vitrina expositora helados

Serie  
**ARIES**  
Series

## CARACTERÍSTICAS TÉCNICAS

### Control



Mayor precisión en el sistema de control de la temperatura y humedad. Mayor facilidad para el ajuste del intervalo de temperaturas que deseamos conseguir.

### Iluminación



Incorporación de **iluminación LED**, llegando a **reducir** el consumo energético **entre un 80% y 90%**.

## TECHNICAL CHARACTERISTICS

### Control

Higher precision in managing temperature settings. Greater ability to adjust of temperature ranges as per the end user's requirement.

### Lighting

**LED lighting** incorporated, **reducing** energetic consumption **between 80% and 90%**.

VAR 18 H



**COLOR RAL**  
**Independiente**

MOD.

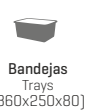

MOD.	Costados Sides (mm)	Potencia Power (W)	Superficie Exposición (m2)	Bandejas Trays (360x165x150)	Bandejas Trays (360x250x80)	Compresor Compressor (HP)	Led	Consumo Consumption (kWh/24h)	Evaporación Evaporation	Control	Refrigerante Coolant
VAR12H	40+40	1250	1,02	14	8	1 1/4	✓	17,5	Forzada Forced	Digital	R-452
VAR15H	40+40	1570	1,26	16	10	1 1/2	✓	24,5	Forzada Forced	Digital	R-452
VAR18H	40+40	1925	1,51	20	14	1 1/4 + 3/4	✓	30,8	Forzada Forced	Digital	R-452



# Gelato display case

Serie  
**ARIES**  
Series

## REFRIGERACIÓN



### Refrigeración

Sistema de **condensación ventilada**.

**Control temperatura** final del desescarche.

Desescarche por **gas caliente**.

## REFRIGERATION

### Refrigeration

**Forced air refrigeration** system.

**Control** of the final defrost **temperature**.

**Hot gas** defrost.

VAR 18 H



**RAL 5015**  
**Azul**  
Blue



**Cortina nocturna**  
Night curtain



**Bandeja evaporativa extraíble**  
Removable evaporation tray



**VAR 12H**  
**7.155 €**

1250 x 1145 x 1320 mm.  
Temp. -15°C / -18°C  
C. Clima. 7  
230v/1ph/50 Hz



**VAR 15H**  
**8.316 €**

1562 x 1145 x 1320 mm.  
Temp. -15°C / -18°C  
C. Clima. 7  
230v/1ph/50 Hz

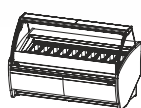

**VAR 18H**  
**9.134 €**

1875 x 1145 x 1320 mm.  
Temp. -15°C / -18°C  
C. Clima. 7  
230v/1ph/50 Hz

**Combinación de bandejas**  
**[360x165x150]**  
Tray combinations [360x165x150]

[501X32] x 14uds. **591 €**

[501X32] x 16uds. **676 €**

[501X32] x 20uds. **845 €**

**Combinación de bandejas**  
**[360x250x80]**  
Tray combinations [360x250x80]

[501X36] x 8uds. **346 €**

[501X36] x 10uds. **433 €**

[501X36] x 14uds. **606 €**

**230v/1ph/60 Hz +6%**

**Medidas sin costados**  
Measures without sides

Fotografías no contractuales / Non contractual pictures.

Características técnicas y constructivas sujetas a variación sin previo aviso / We reserve the right to change specifications without prior notice.

Los datos técnicos están sujetos a posibles variaciones que serán actualizadas periódicamente en las fichas técnicas del producto, disponibles en la web.

The technical data are subject to possible variations that will be updated periodically in the technical data sheets of the product, which are available on the website.

www.infrico.com



553



## COMBINACIÓN DE BANDEJAS

## COMBINATION OF TRAYS

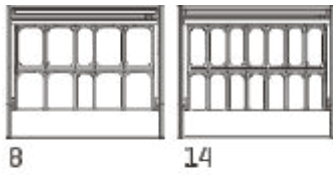

8

14

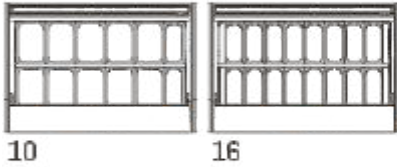

10

16

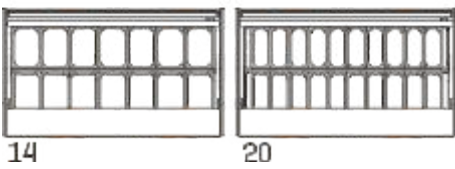

14

20

### Combinación de bandejas [360x250x80]

Tray combinations [360x250x80]

[501X36] x 8 uds. **346 €**

[501X36] x 10 uds. **433 €**

[501X36] x 14 uds. **606 €**

### Combinación de bandejas [360x165x150]

Tray combinations [360x165x150]

[501X32] x 14 uds. **591 €**

[501X32] x 16 uds. **676 €**

[501X32] x 20 uds. **845 €**

## CUBETA PORTAPOLOS [consultar]

## ICE LOLLY HOLDER TRAY [to consult]



Consultar / Consult



# Gelato case

Serie  
**CORAL & ARIES**  
Series

## Decoraciones / Decorations



**VCB H**  
**RAL 3003**  
Granate / Maroon



**VCB H**  
**RAL DESIGN 2108025**  
Celeste / Sky blue

**VCB H**  
**RAL 9016**  
Blanco / White



**VCB H**  
**RAL 2003**  
Naranja / Orange



## Decoración Standard / Standar Decorations

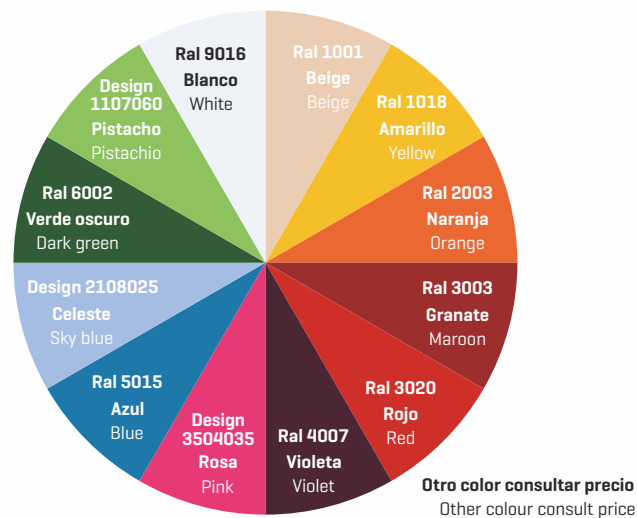

## Colores fuera de carta / Colors outside of letter

Color	Tipo Type	Incremento plazo de entrega Increase delivery time	Suplemento PVP [x pedido] PVP supplement [x order]
RAL	Epoxi	+10 días laborables/ Work days	675,00 €
	Líquida/Liquid	+10 días laborables/ Work days	420,00 €
NO RAL	Epoxi	Consultar/Consulter	Consultar/Consulter
	Líquida/Liquid	Consultar/Consulter	Consultar/Consulter

Fotografías no contractuales / Non contractual pictures.

Características técnicas y constructivas sujetas a variación sin previo aviso / We reserve the right to change specifications without prior notice.

Los datos técnicos están sujetos a posibles variaciones que serán actualizadas periódicamente en las fichas técnicas del producto, disponibles en la web.

The technical data are subject to possible variations that will be updated periodically in the technical data sheets of the product, which are available on the website.







# Vitrina expositora helado frío estático

## Ice cream static display case



11



Serie  
**IBIZA**  
Series



V. PASTELERIA  
PASTRY DISPLAY CASES



# Vitrina expositora helado frío estático

Serie  
**IBIZA**  
Series

## CARACTERÍSTICAS TÉCNICAS

### Control



**Mayor precisión** en el sistema de **control de la temperatura y humedad**. Mayor facilidad para el ajuste del intervalo de temperaturas que deseamos conseguir.

### Iluminación



Incorporación de **iluminación LED**, llegando a **reducir** el consumo energético **entre un 80% y 90%**.

## TECHNICAL CHARACTERISTICS

### Control

**Higher precision** in managing **temperature settings**. Greater ability to adjust of temperature ranges as per the end user's requirement.

### Lighting

**LED lighting** incorporated, **reducing** energetic consumption **between 80% and 90%**.

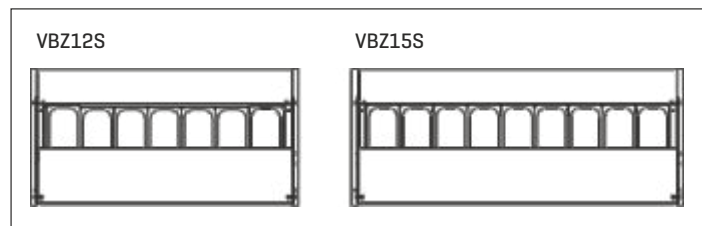
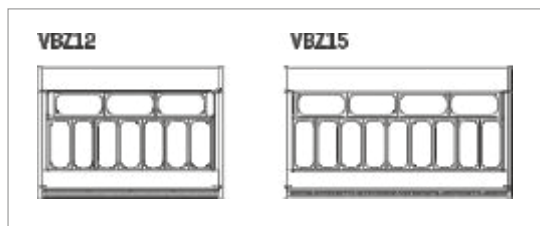

MOD.	Potencia Power (W)	Capacidad Capacity (L)	Superficie Exposición (m <sup>2</sup> )	Bandejas Trays (360x165x150)	Compresor Compressor (HP)	LED	Consumo Consumption (kWh/24h)	Evaporación Evaporation	Potencia frigorífica Cooling capacity (W a -10°C)	Desescarche Defrost	Control	Refrigerante Coolant
VBZ 12	445	289	0,72	10+10	3/8	✓	7,1	Estática Static	472	Automático Automatic	Digital	R-452
VBZ 15	465	361	0,89	13+13	3/8	✓	7,4	Estática Static	472	Automático Automatic	Digital	R-452
VBZ 12S	510	210	0,50	7+7	1/3	✓	11,2	Estática Static	399	Automático Automatic	Digital	R-452
VBZ 15S	530	263	0,63	9+9	1/3	✓	11,5	Estática Static	399	Automático Automatic	Digital	R-452



# Ice cream static display case

Serie  
**IBIZA**  
Series

## REFRIGERACIÓN



### Refrigeración

Exposición **helado** [-15°C / -18°C].  
Reserva **cupeta** [-18°C].

## REFRIGERATION

### Refrigeration

**Ice cream** exhibition [-15°C / -18°C].  
**Tray** storage [-18°C].

**VBZ12 S**



### Combinación de bandejas (360x165x150)

Tray combinations (360x165x150)

VBZ12 (501x32) x 10 uds. **422 €**

VBZ15 (501x32) x 13 uds. **549 €**

### Combinación de bandejas (360x165x150)

Tray combinations (360x165x150)

VBZ12S (501x32) x 7 uds. **296 €**

VBZ15S (501x32) x 9 uds. **380 €**



**VBZ12**  
**3.339 €**

1310 x 920 x 1350 mm.  
Temp. -15°C / -18°C  
C. Clima. 4 / 38°C  
230v/1 ph/50 Hz

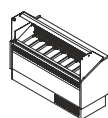

**VBZ15**  
**3.616 €**

1622 x 920 x 1350 mm.  
Temp. -15°C / -18°C  
C. Clima. 4 / 38°C  
230v/1 ph/50 Hz



**VBZ12S**  
**2.868 €**

1310 x 670 x 1350 mm.  
Temp. -15°C / -18°C  
C. Clima. 4 / 38°C  
230v/1 ph/50 Hz

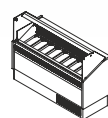

**VBZ15S**  
**3.114 €**

1622 x 670 x 1350 mm.  
Temp. -15°C / -18°C  
C. Clima. 4 / 38°C  
230v/1 ph/50 Hz

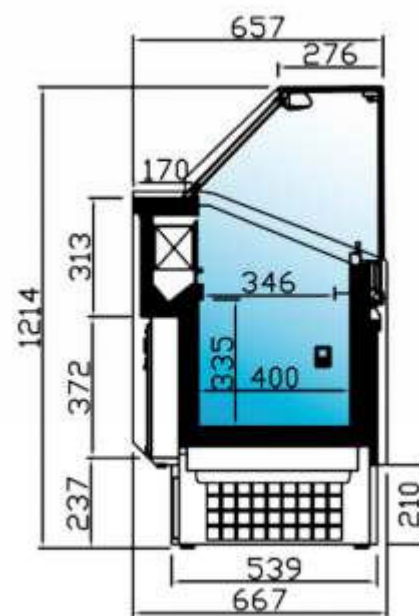

**VBZ**

